

**EN**

**RADIATOR RELOCATION KIT WITH SNORKEL KIT  
INSTALLATION MANUAL**

**DE**

**SCHNORCHEL EINBAU- UND MONTAGEANLEITUNG**

**RU**

**ИНСТРУКЦИЯ ПО УСТАНОВКЕ ВЫНОСА РАДИАТОРА  
С КОМПЛЕКТОМ ШНОРКЕЛЕЙ**



**For: Stels ATV 650 Leopard (2014-)**

2444.6740.1  
444.6740.1



EN Regular fasteners  
DE Originale montageteile  
RU Штатный крепеж



EN Regular fasteners  
DE Originale montageteile  
RU Штатный крепеж



EN Screw a several turns  
DE Für wenigen Umdrehungen befestigen  
RU Вкрутить на несколько оборотов



EN Loosen bolts  
DE Bolzen lockern  
RU Выкрутить на несколько оборотов

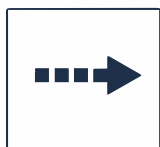

EN Movement Arrow  
DE Bewegungsrichtung  
RU Движение



EN Location/Position Arrow  
DE Anordnung/Positionsrichtung  
RU Расположение



EN Screw Arrow  
DE Drehungsrichtung  
RU Поворот



EN Drill  
DE Bohrer  
RU Дрель

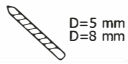

D=5 mm  
D=8 mm

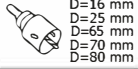

D=16 mm  
D=25 mm  
D=65 mm  
D=70 mm  
D=80 mm



EN Ratchet  
DE Ratsche  
RU Трещётка

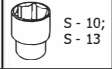

S - 10;  
S - 13



S - 5;  
S - 4



EN Hacksaw  
DE Säge  
RU Ножовка



EN Office Knife  
DE Büromesser  
RU Канцелярский нож



EN Sealant  
DE Dichtmasse  
RU Герметик

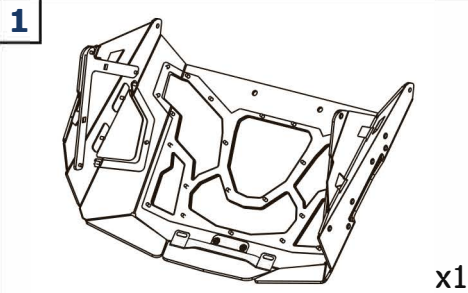

x1

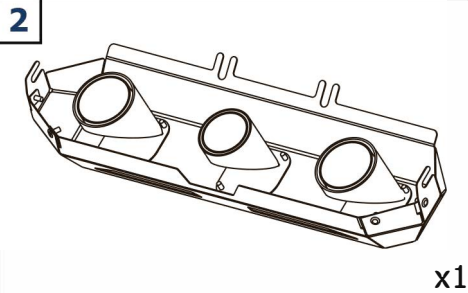

x1

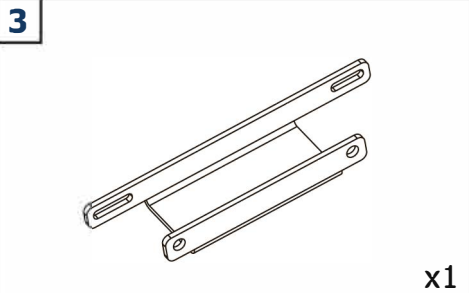

x1

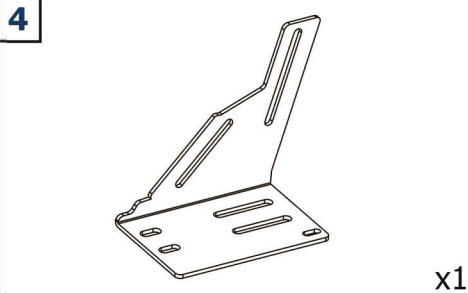

x1

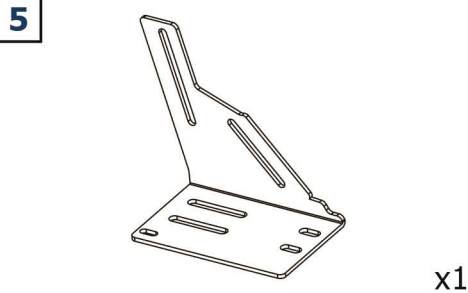

x1

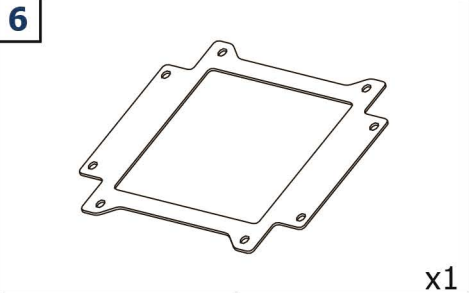

x1

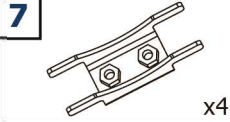

x4

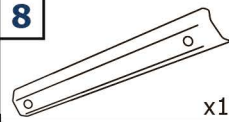

x1

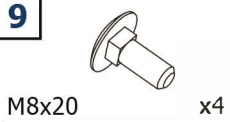

M8x20 x4



x2



x4

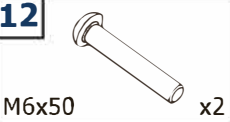

x2



M4x16 x5

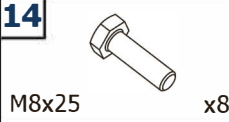

M8x25 x8



M8x25 x6

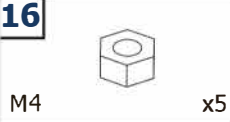

x5



x8



x6



Ø4 x10

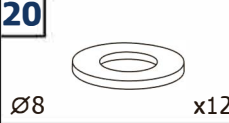

Ø8 x12

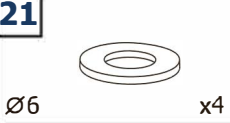

Ø6 x4



x12

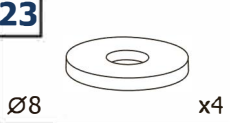

x4

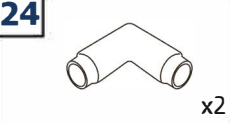

x2



10-16 x2



60-80 x6



20-32 x4



x20



x1

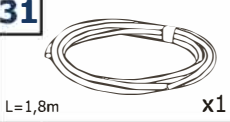

L=1,8m x1

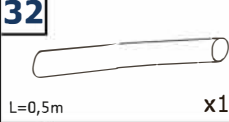

L=0,5m x1



x2

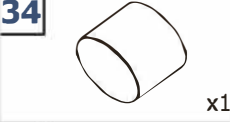

x1

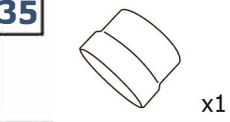

x1



x1

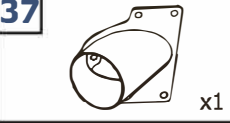

x1



x1

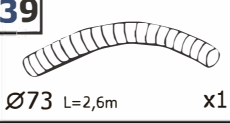

Ø73 L=2,6m x1

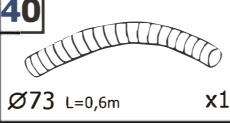

x1

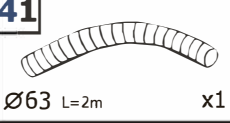

x1

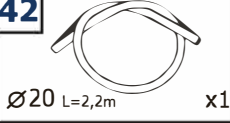

x1

**EN** Attention! All flexible hose couplings are designed with a sealant.

**DE** Achtung! Alle flexiblen Schlauchkupplungen werden mit einem Dichtmittel ausgeführt.

**RU** Внимание! Все соединения гибких рукавов выполняются с использованием герметика

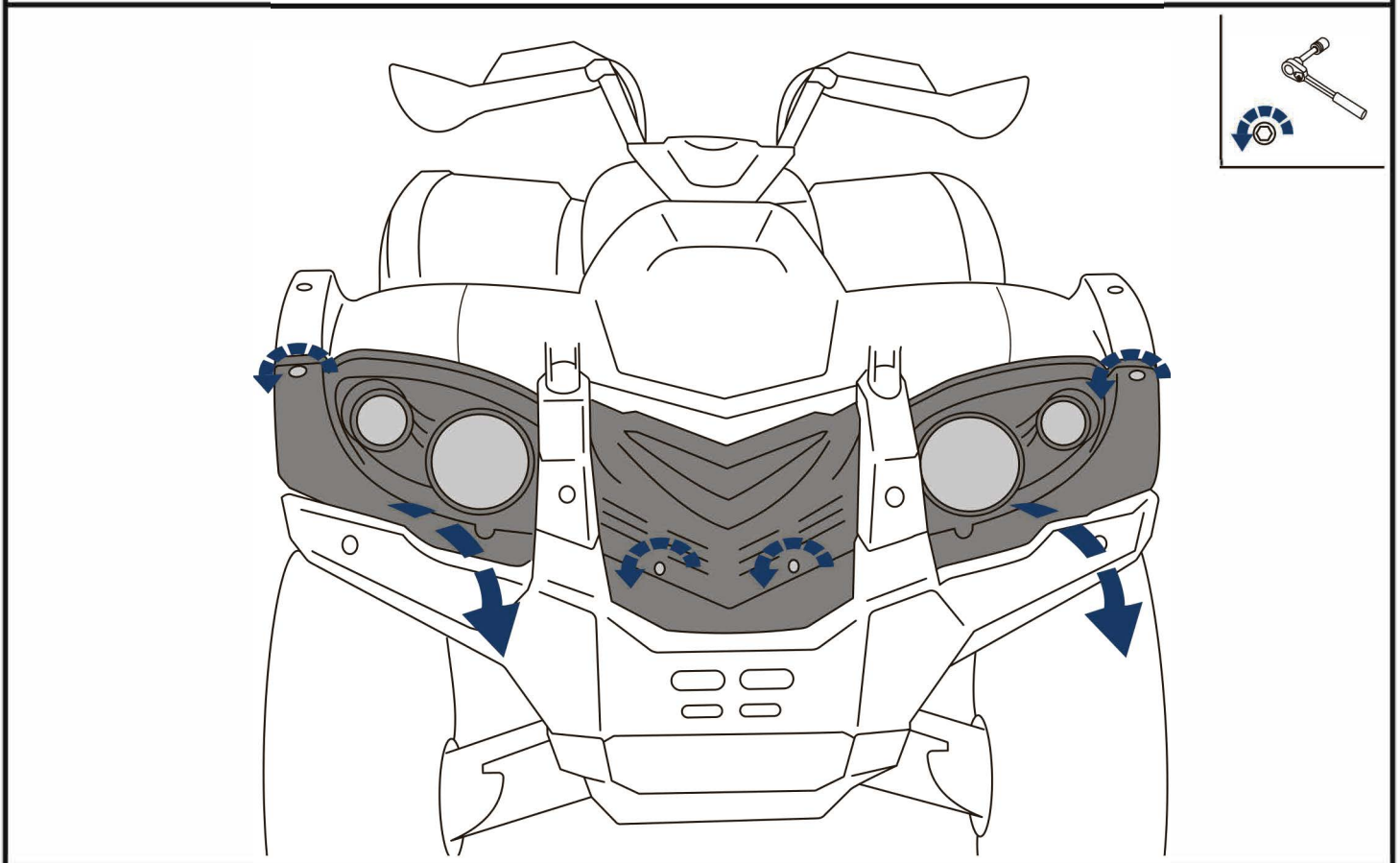
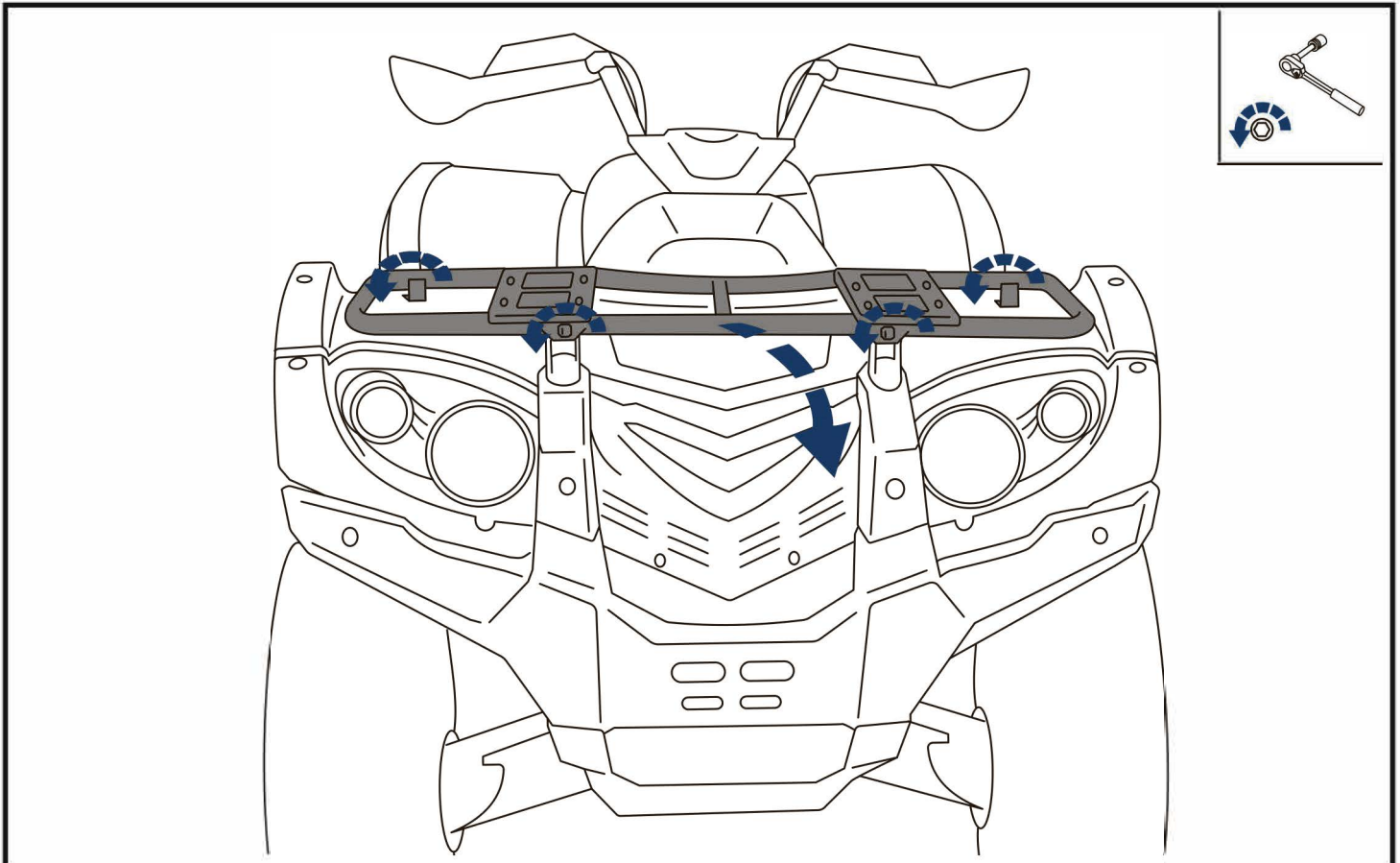



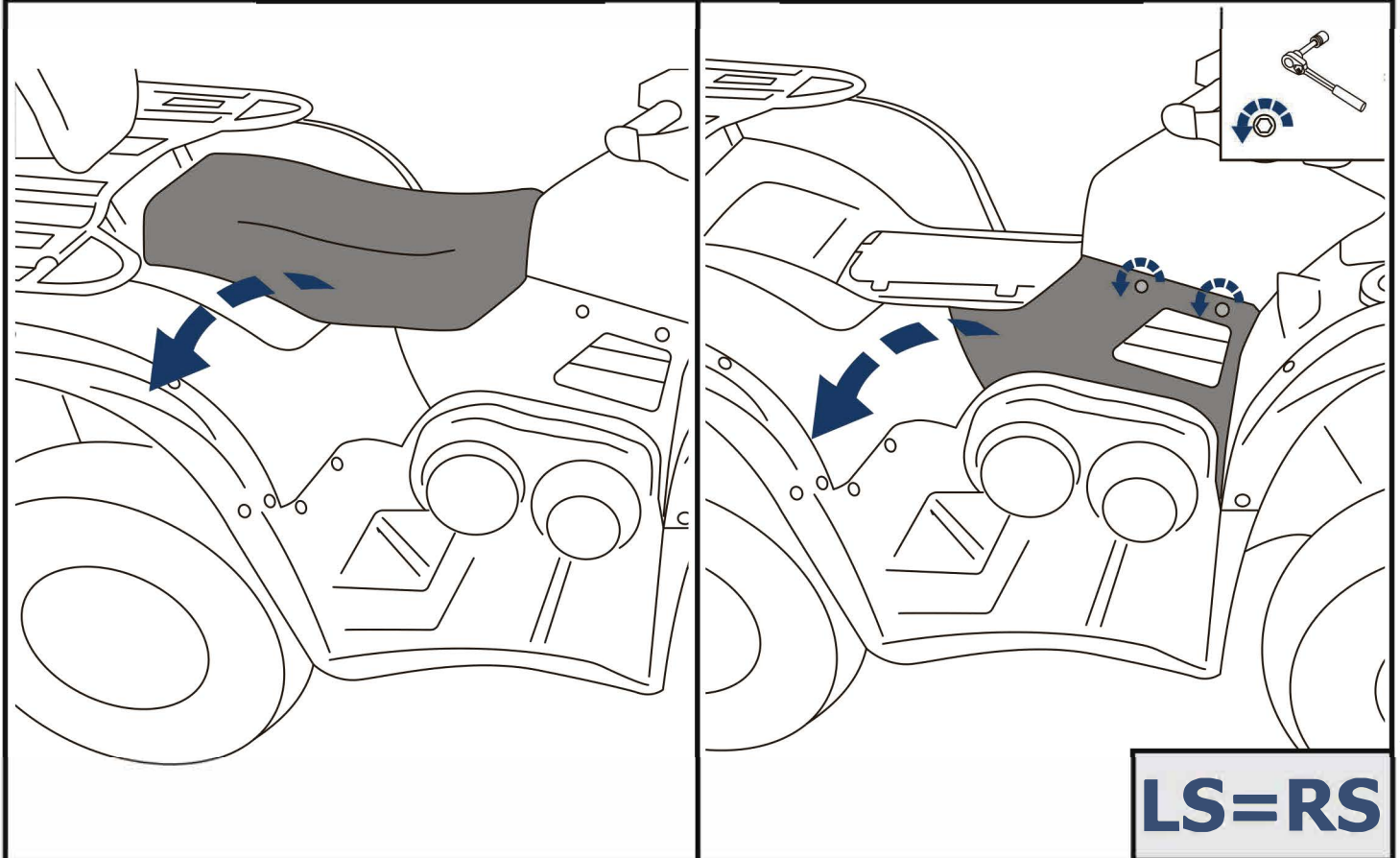
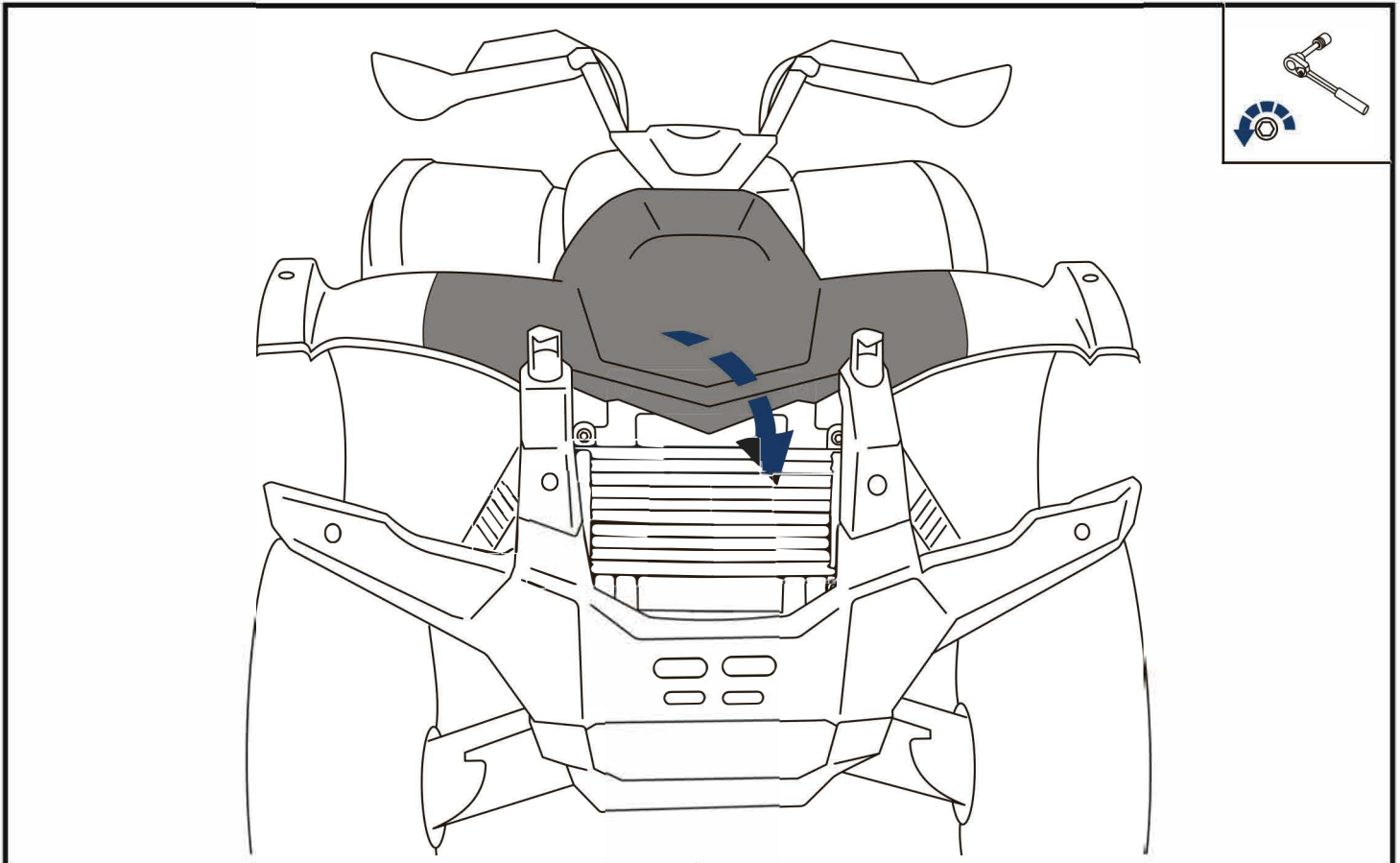

**LS=RS**

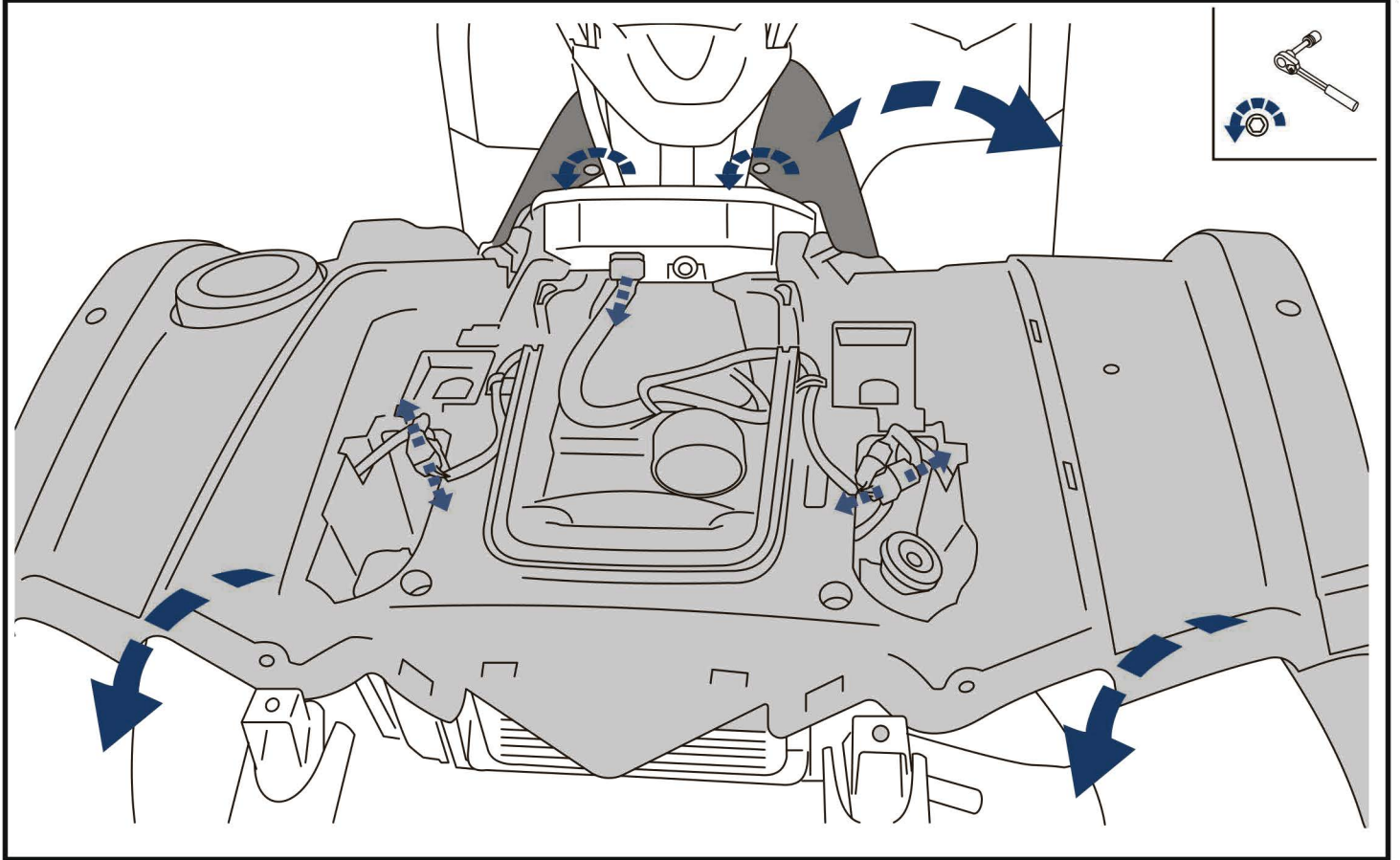
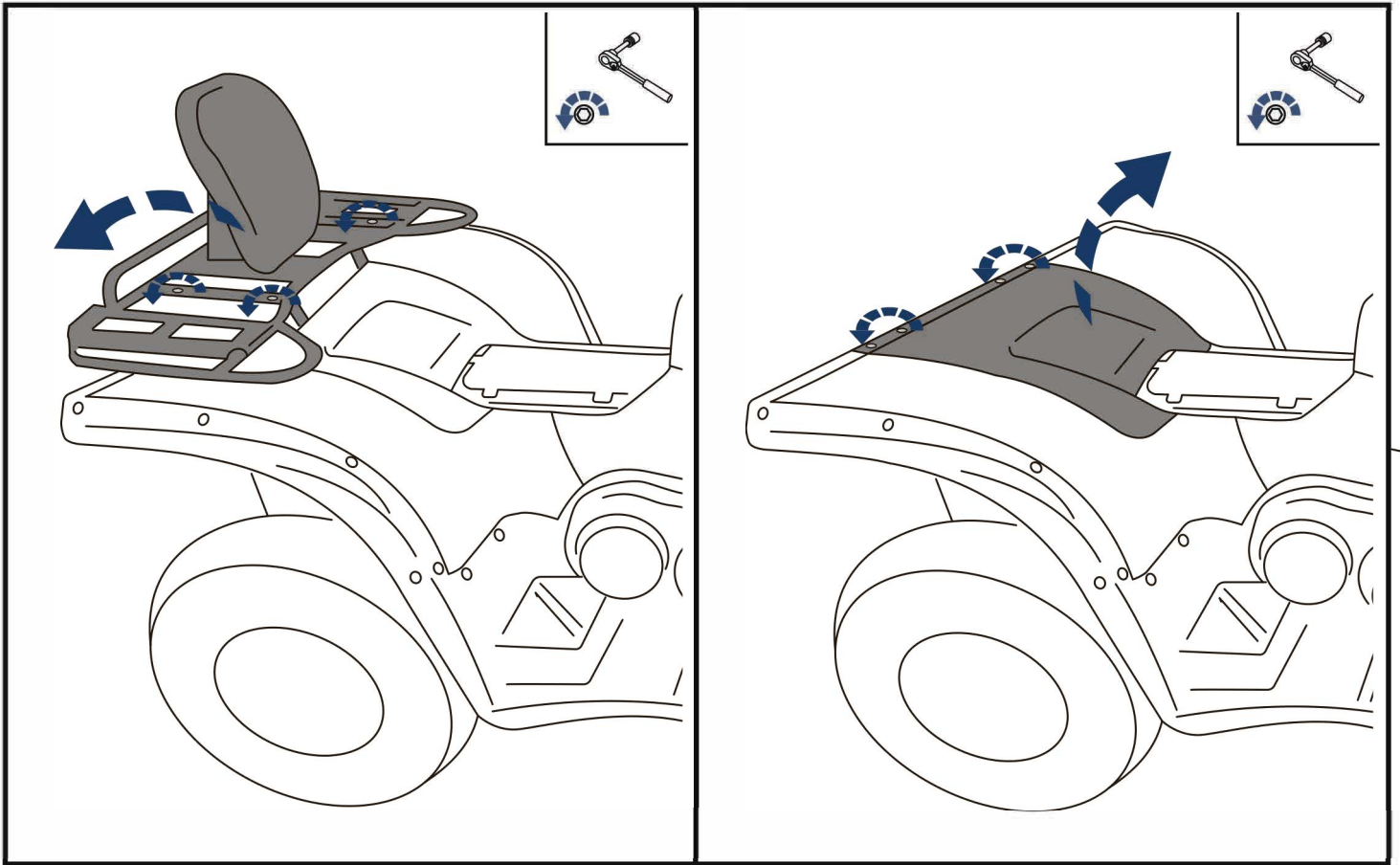

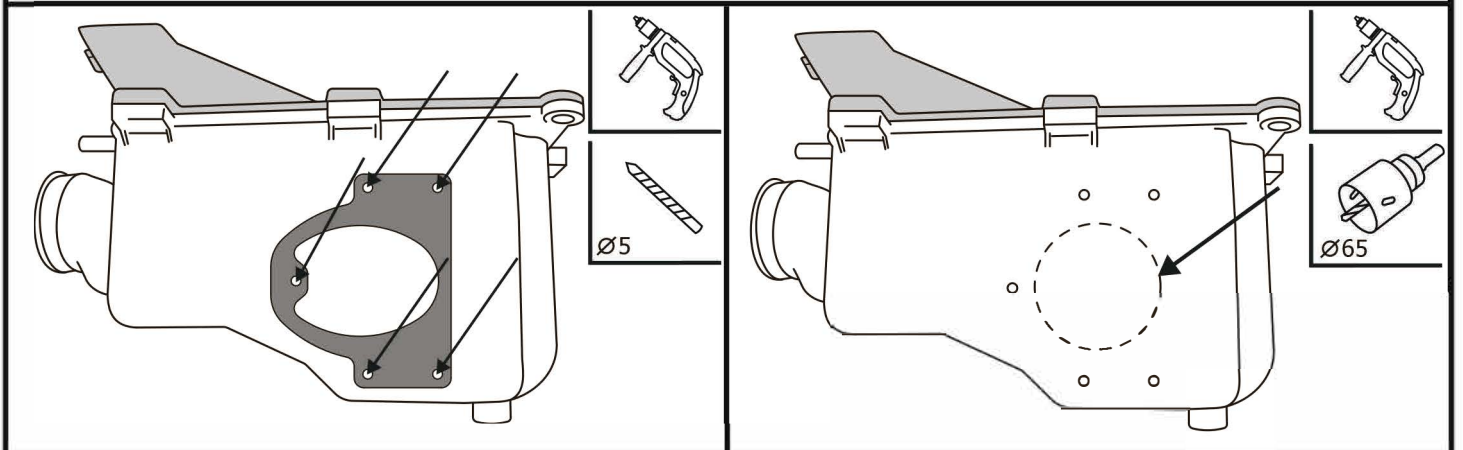
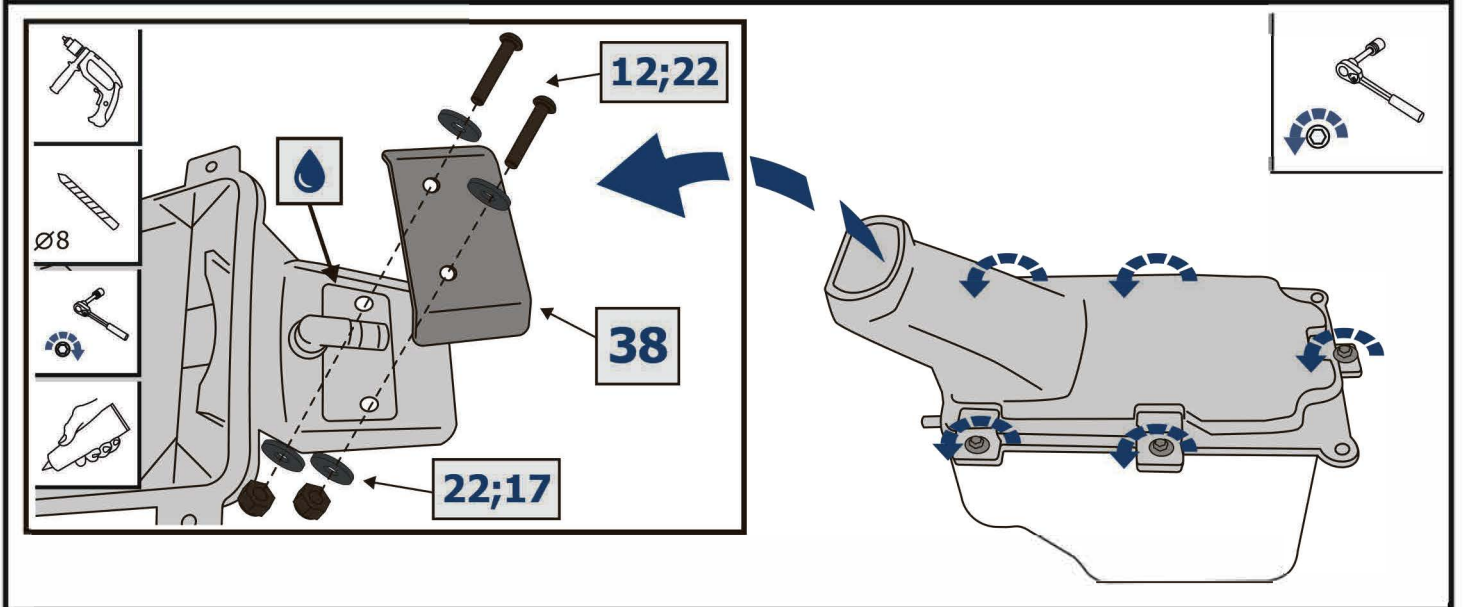
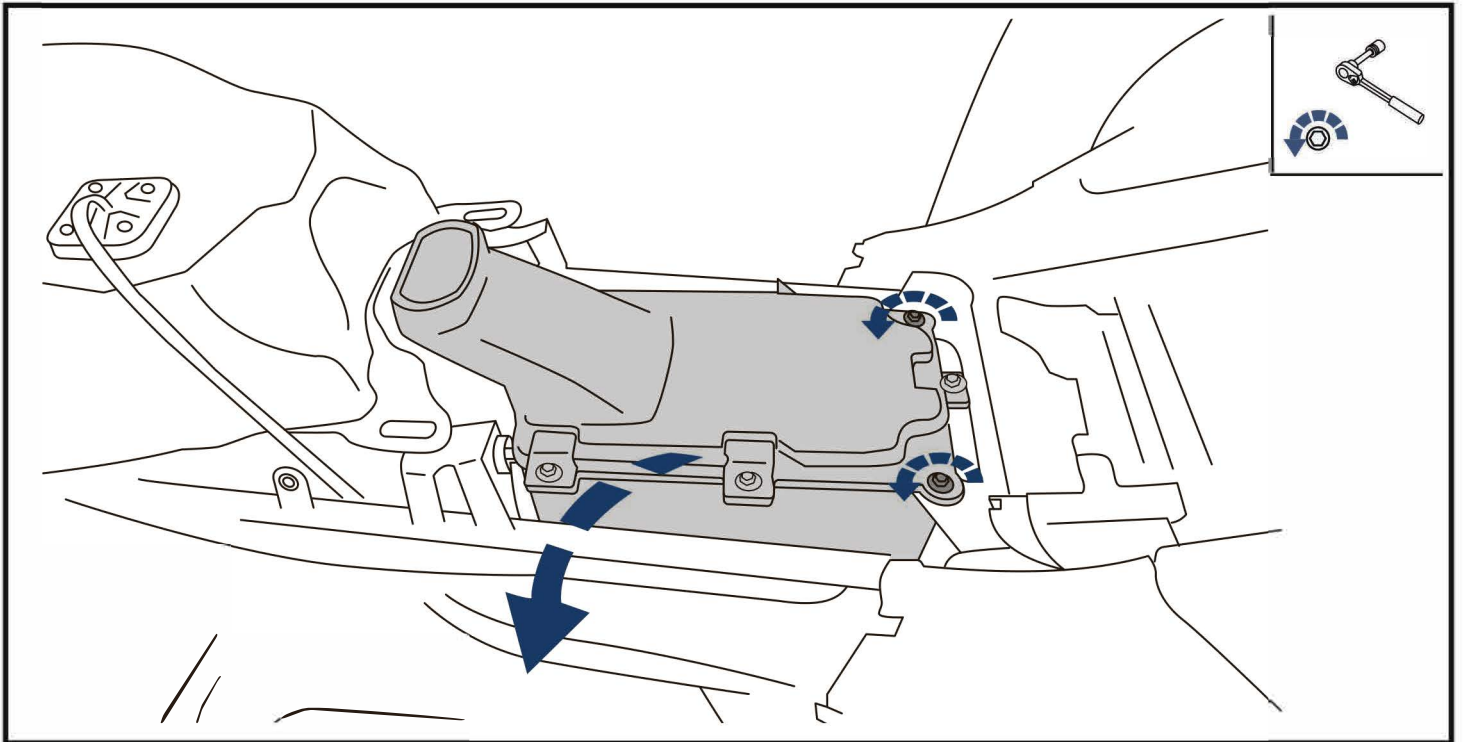



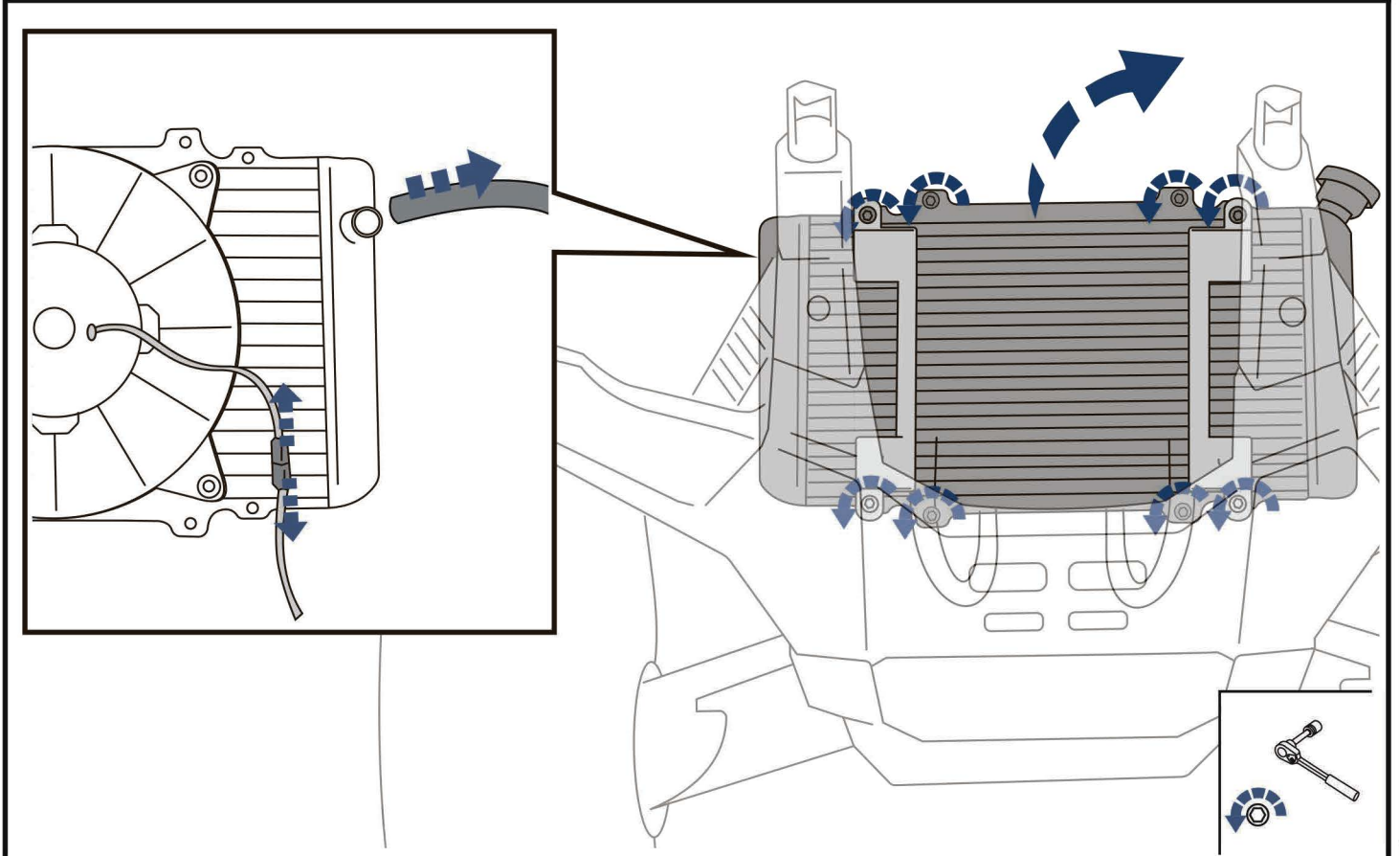
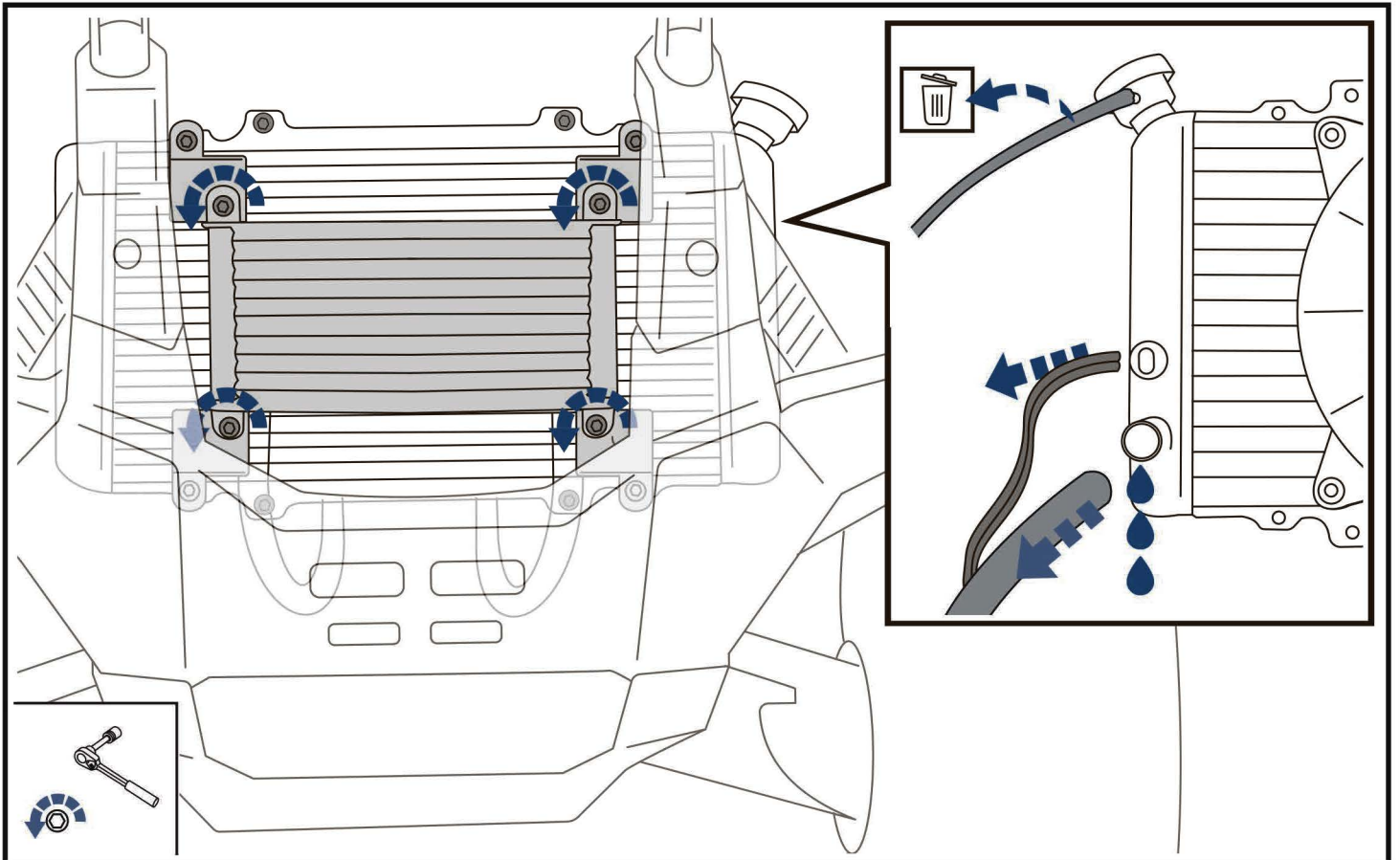



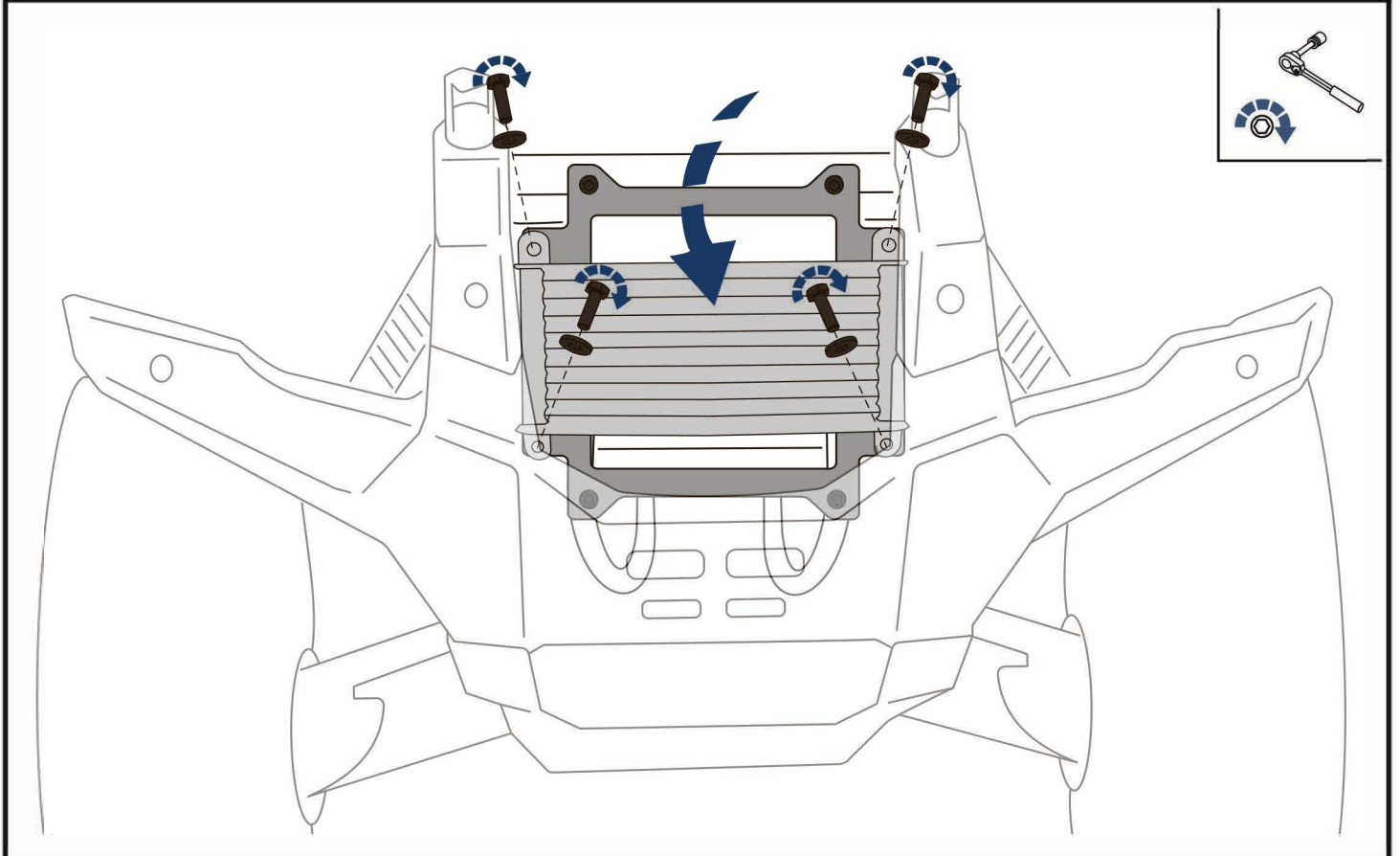
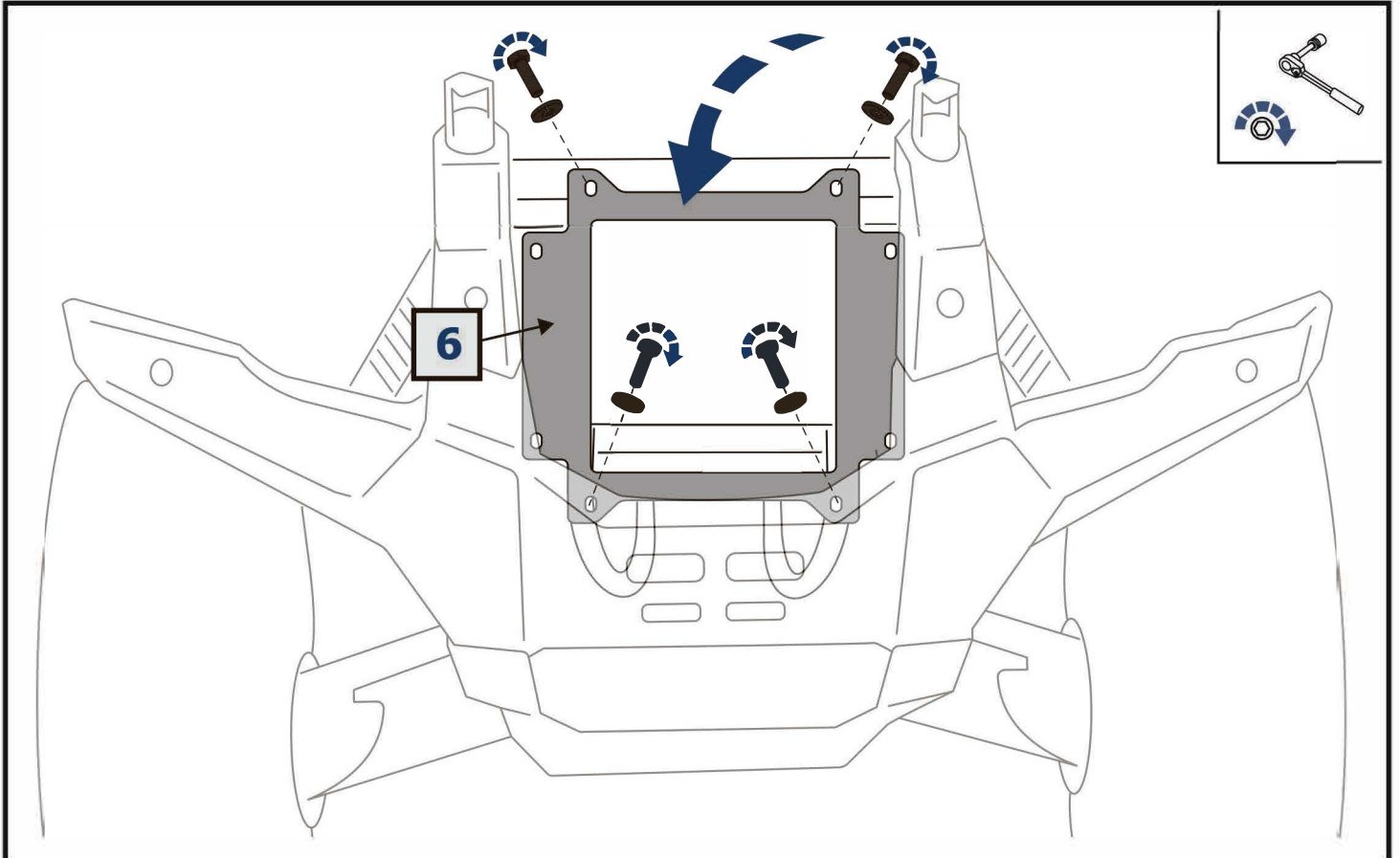

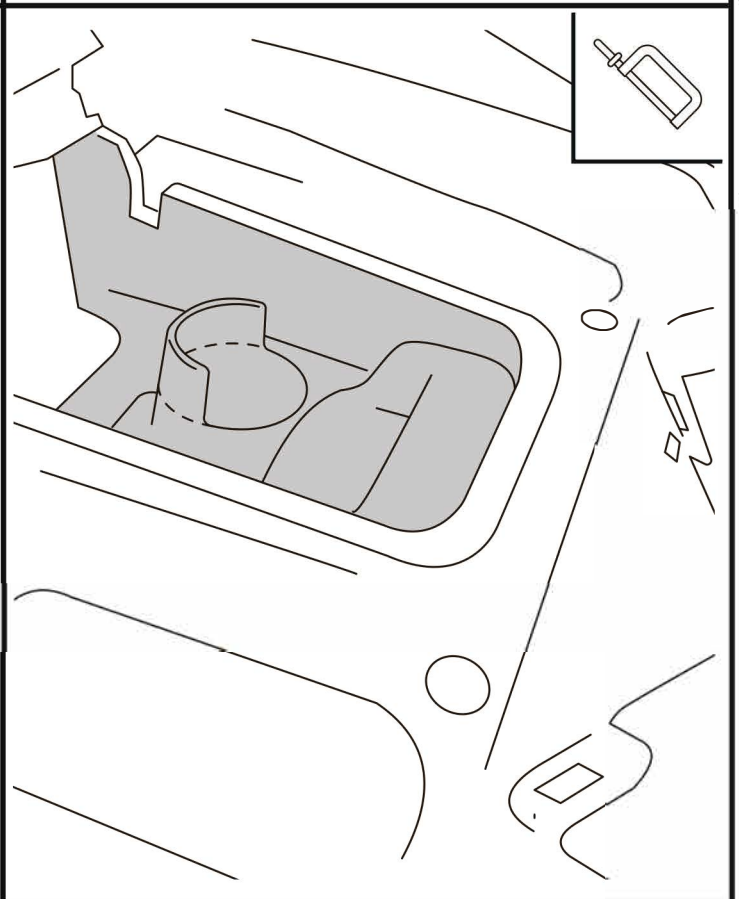
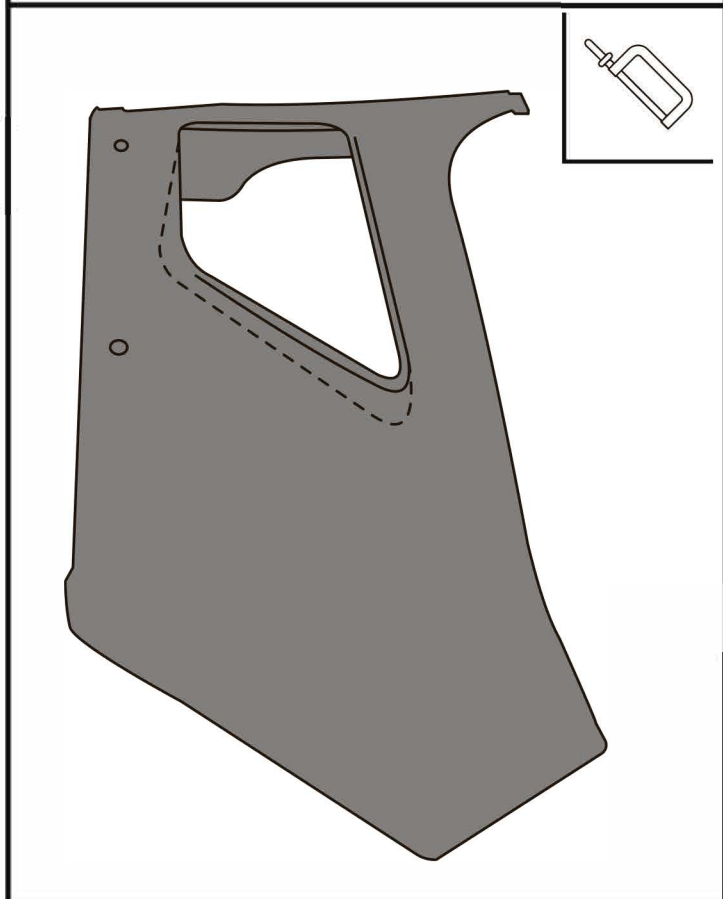
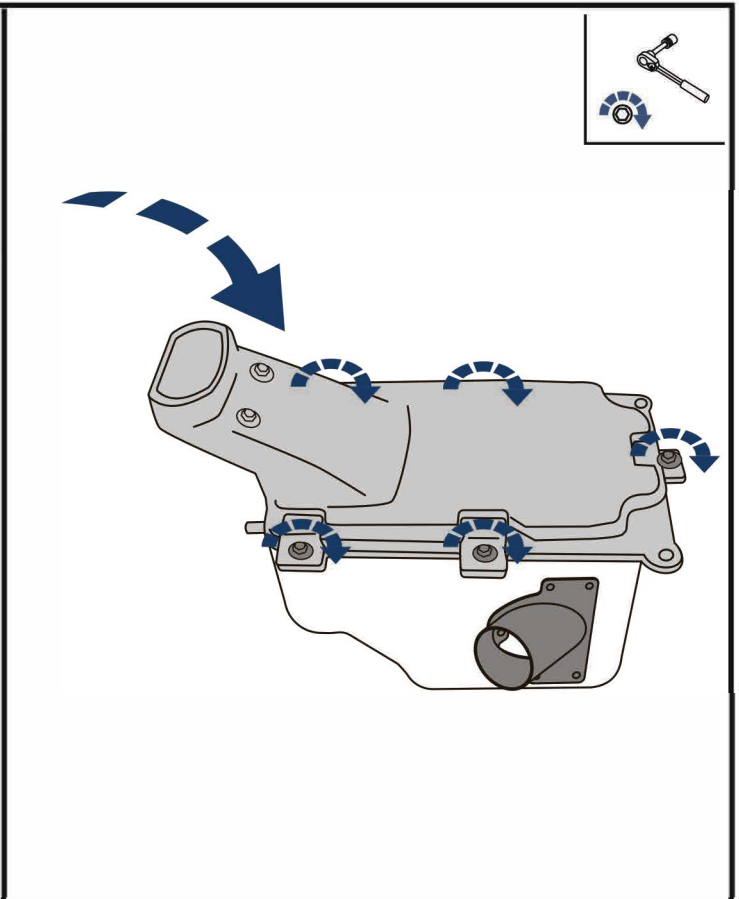
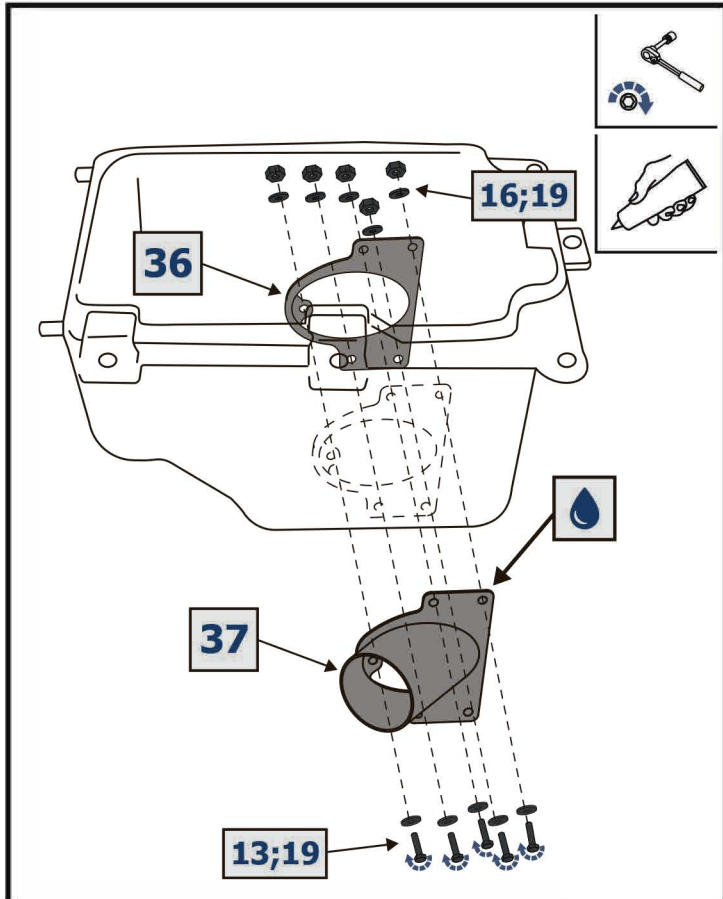

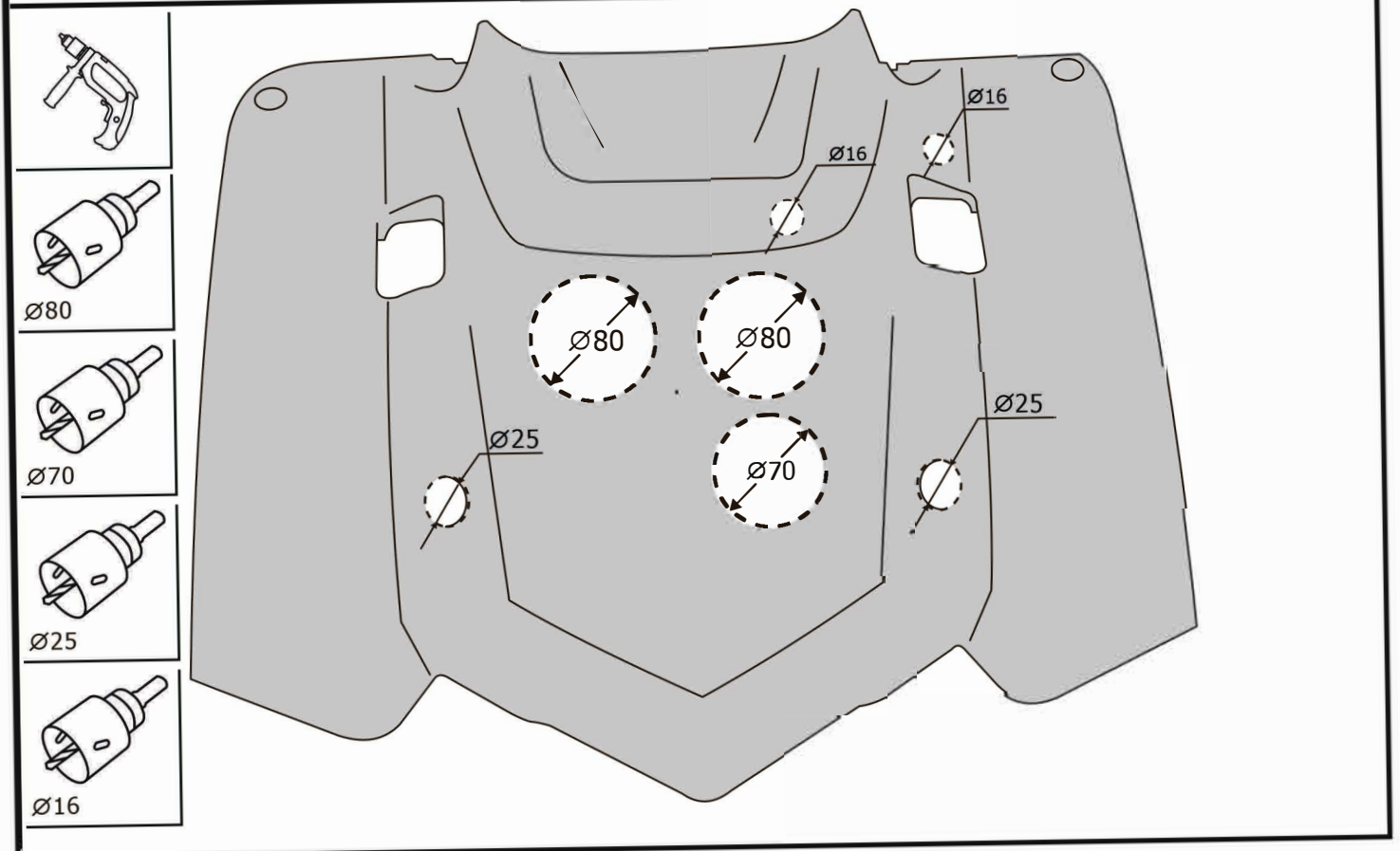
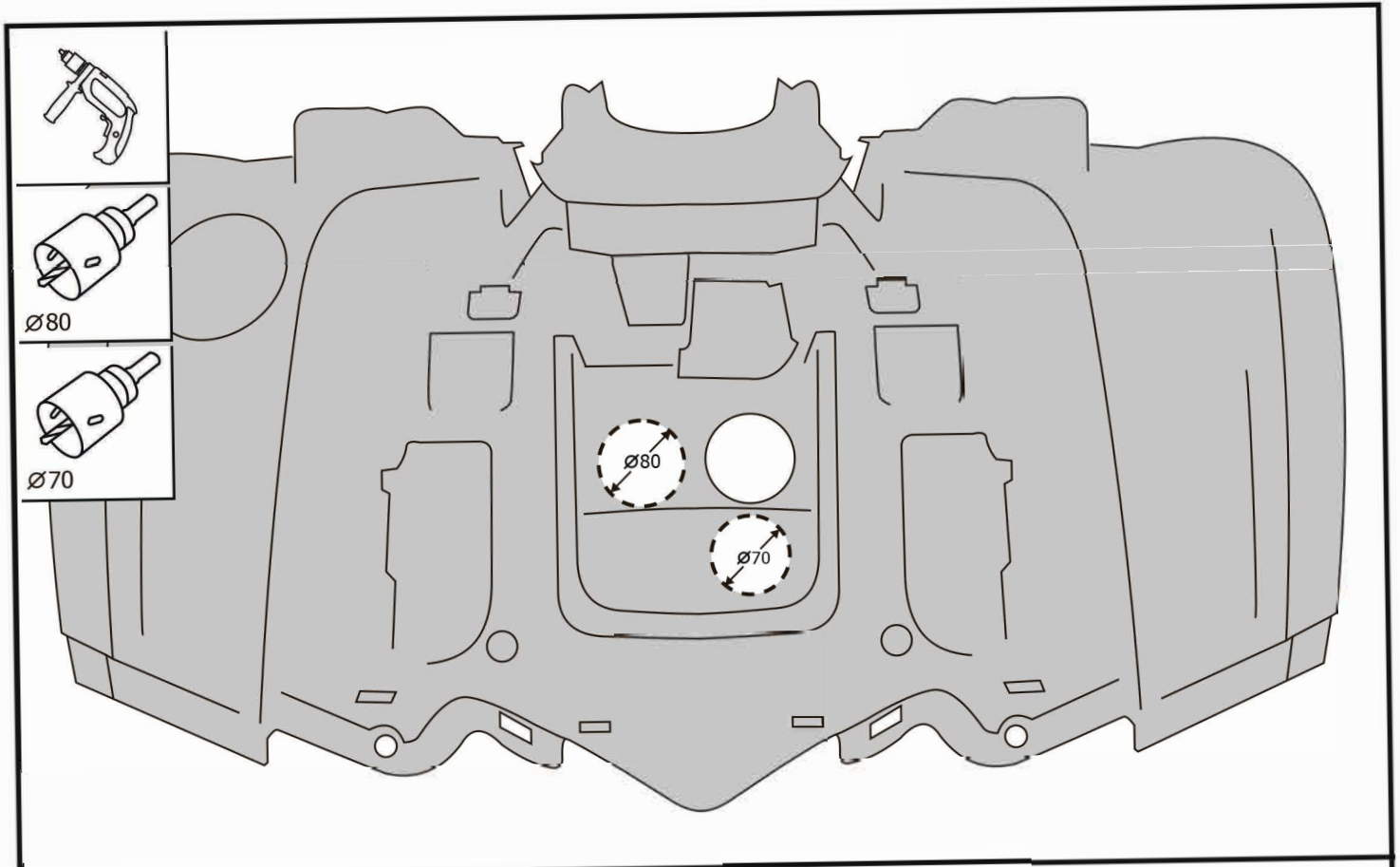

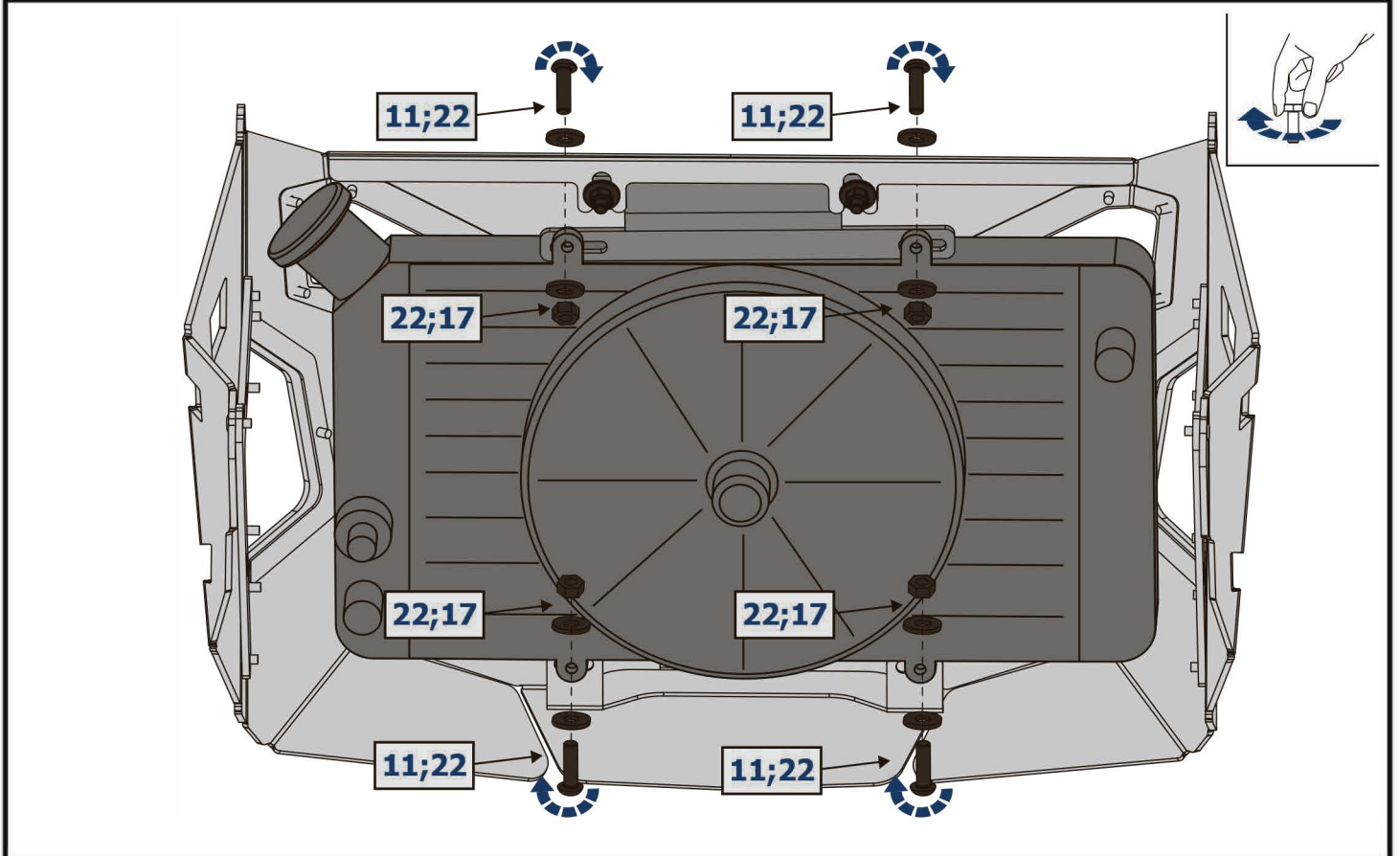
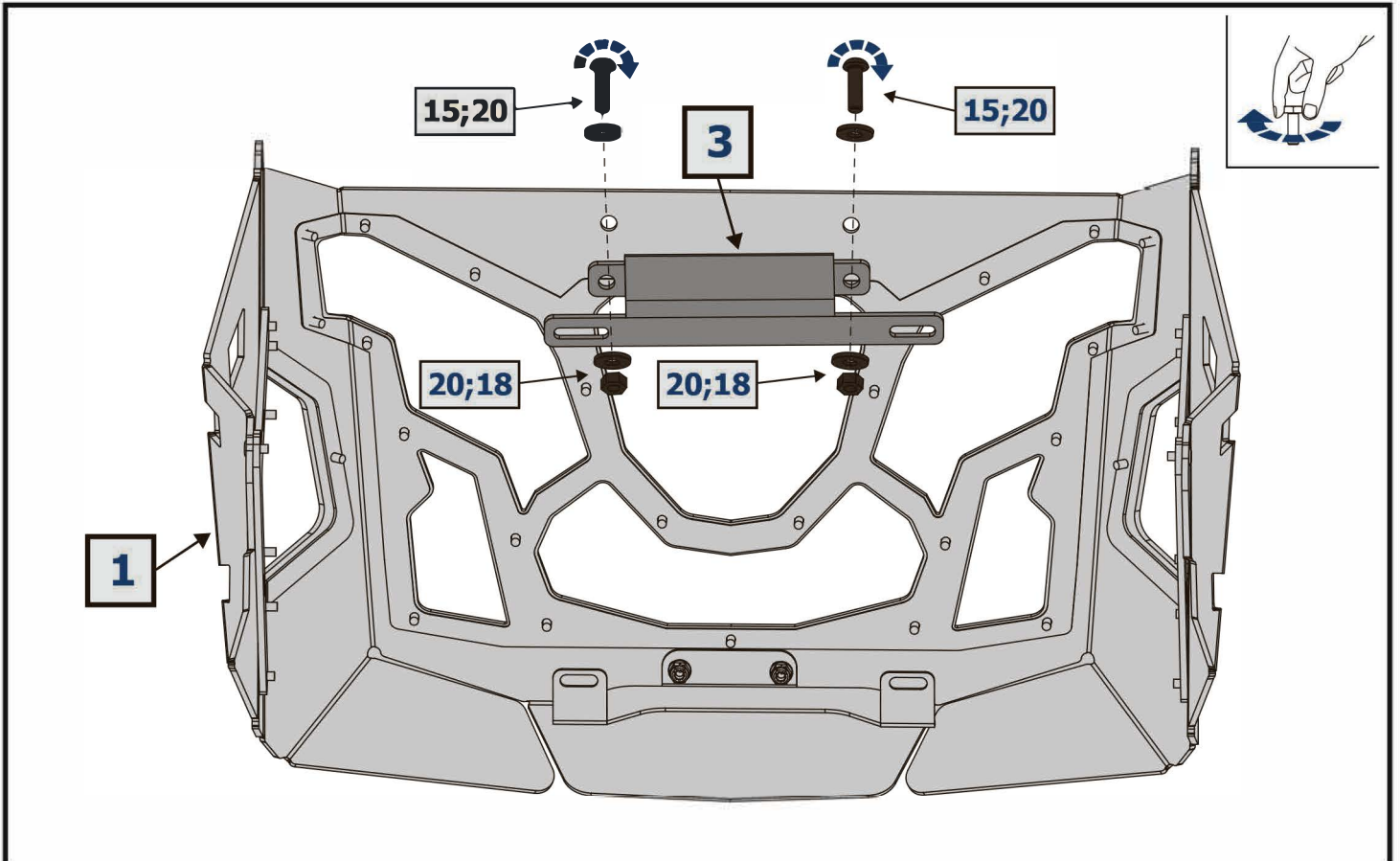



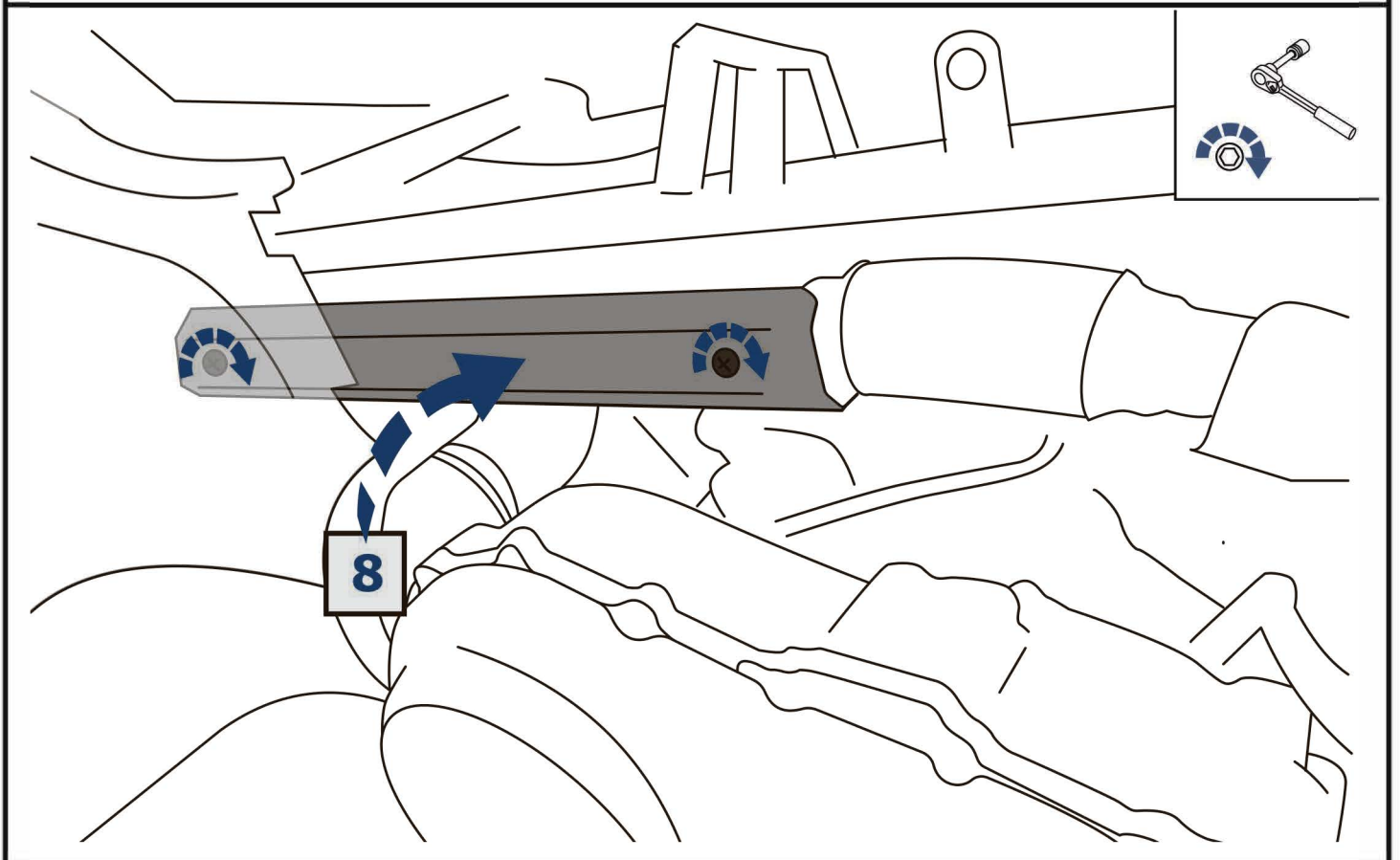
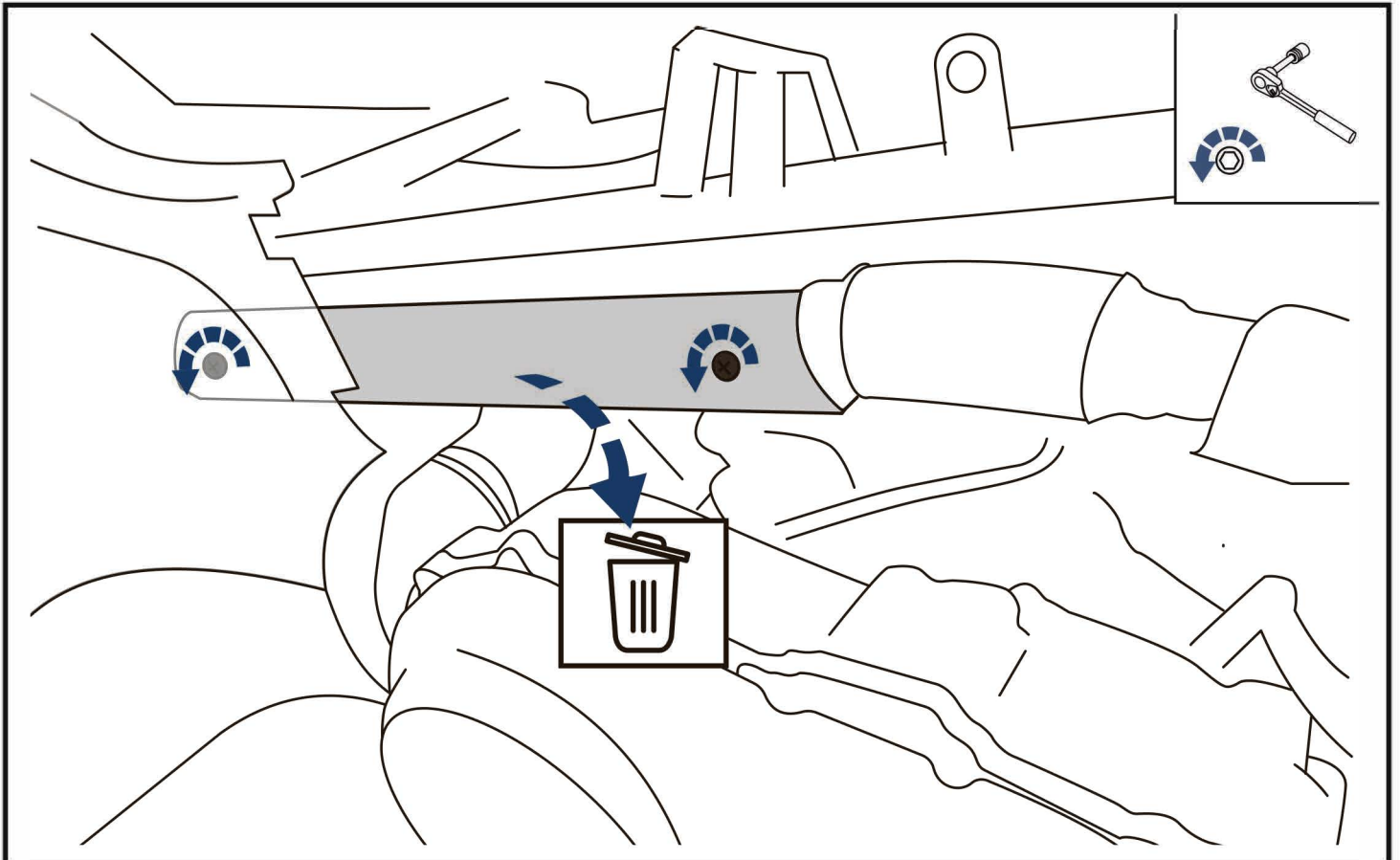

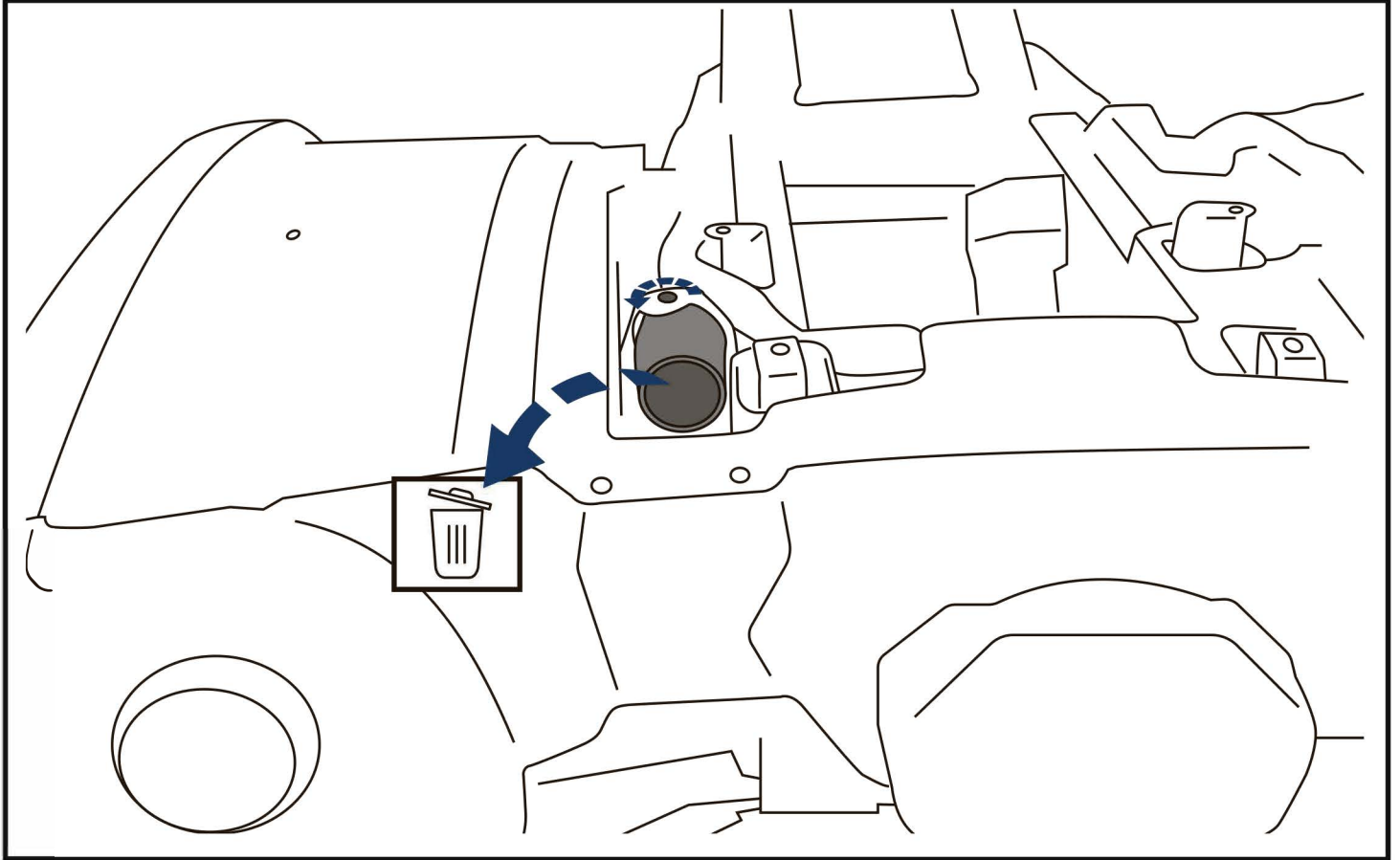
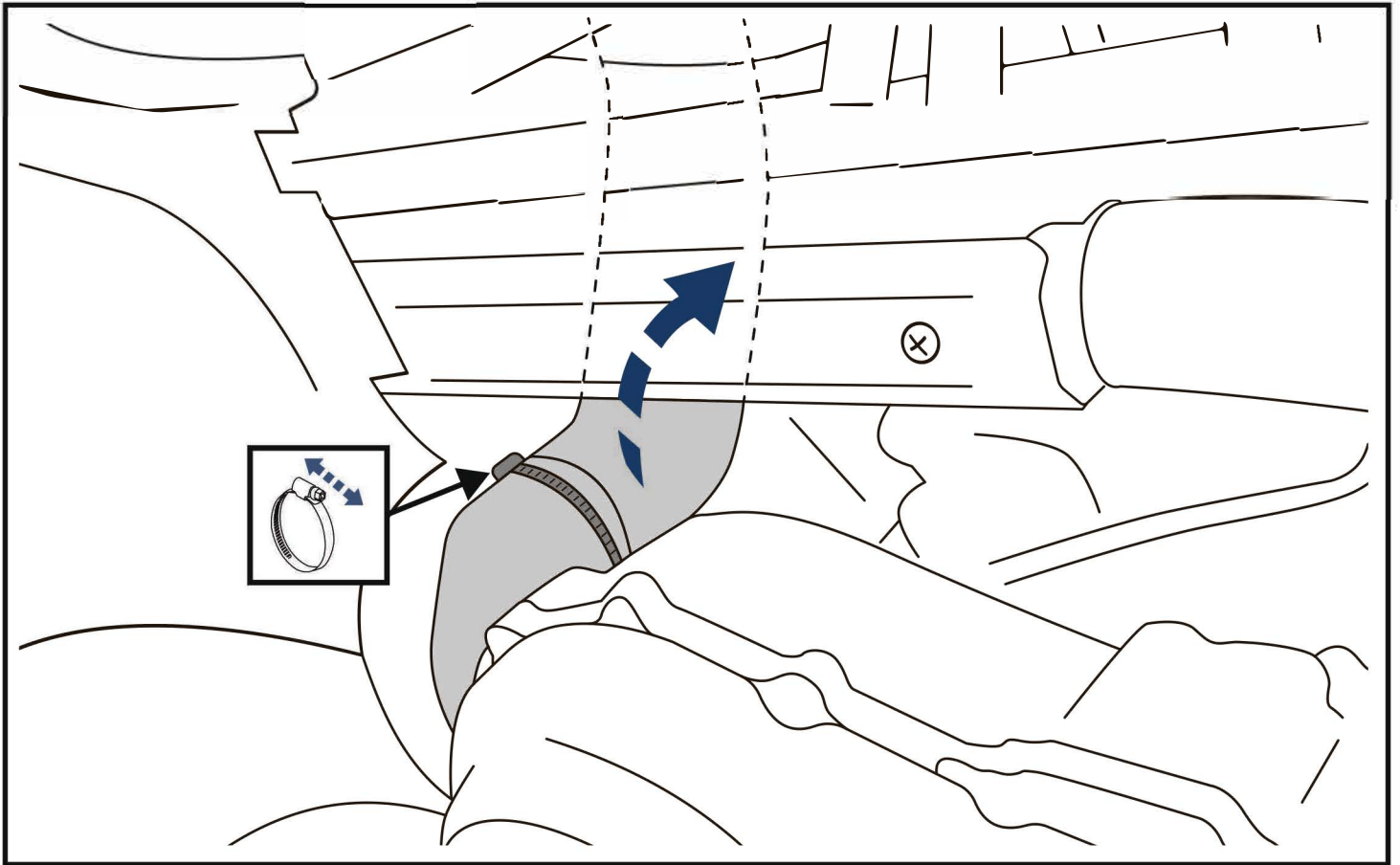

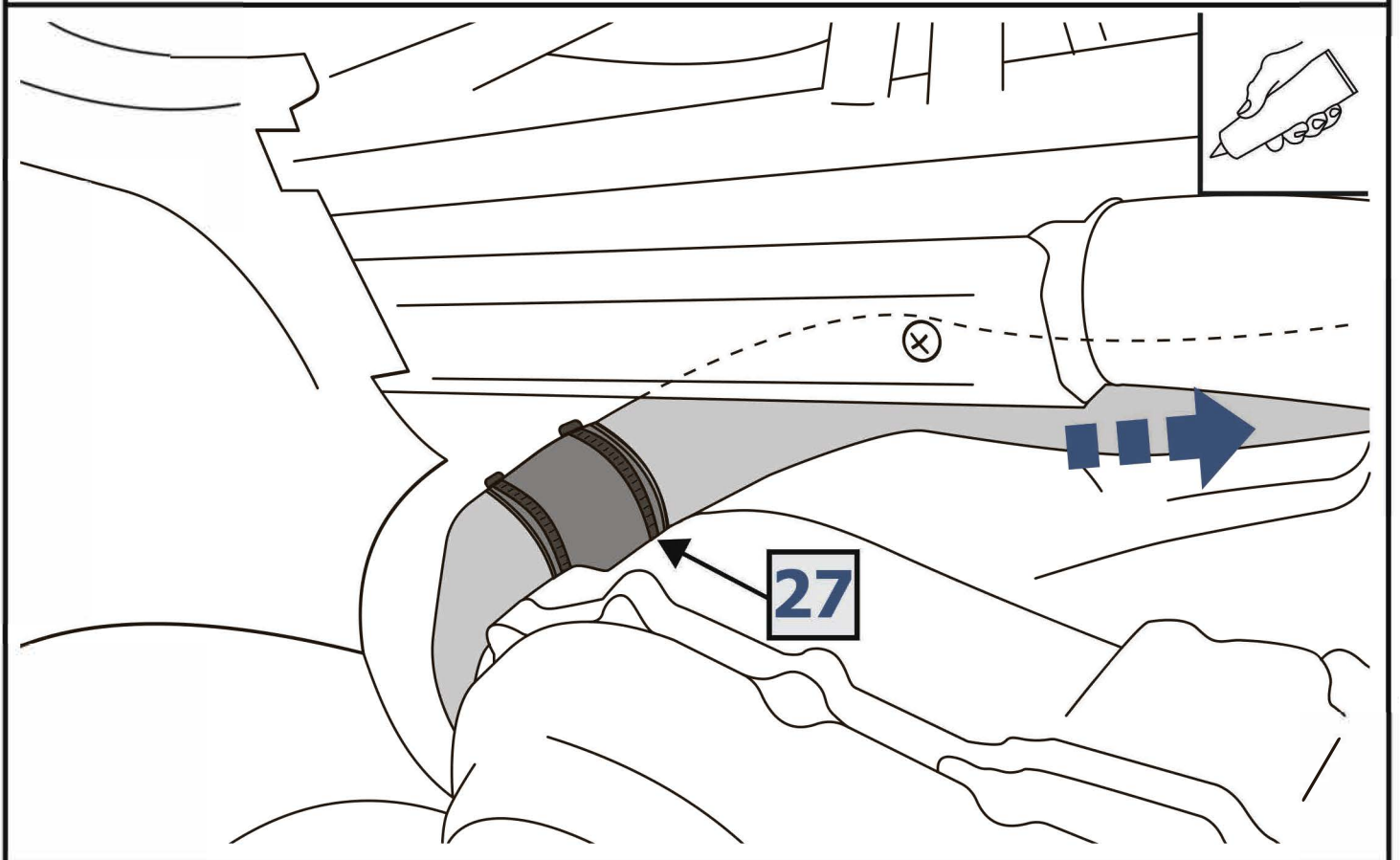
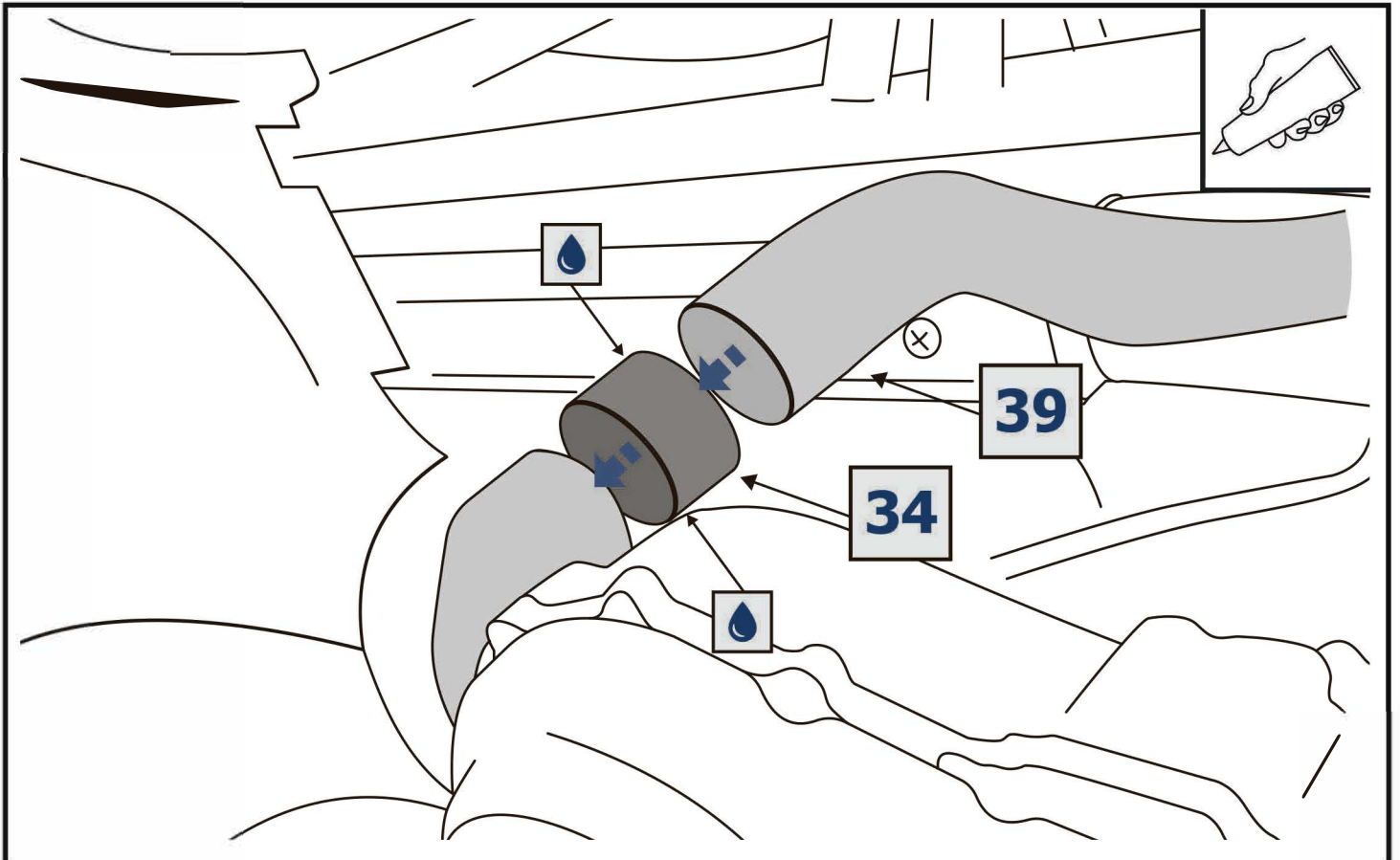

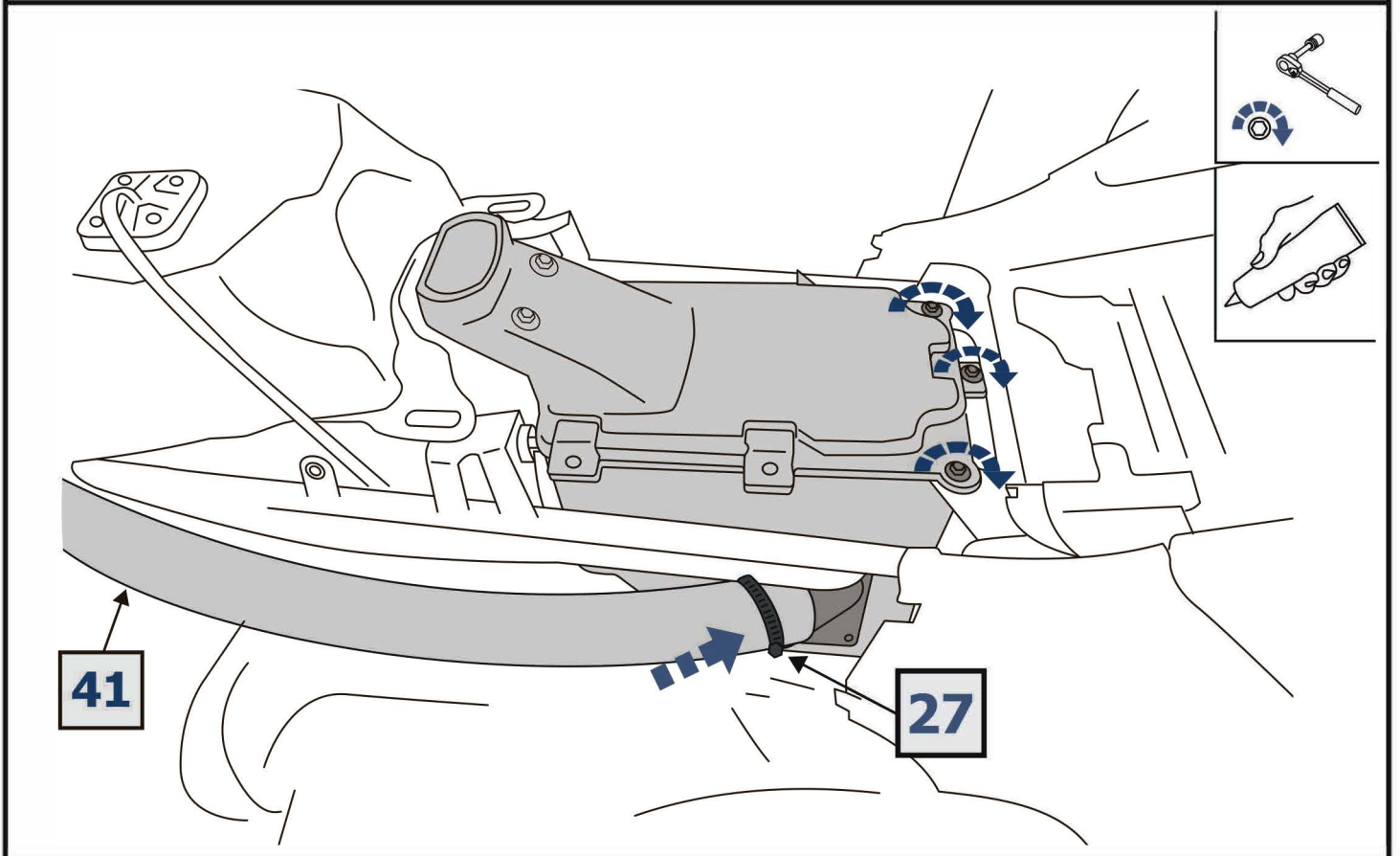
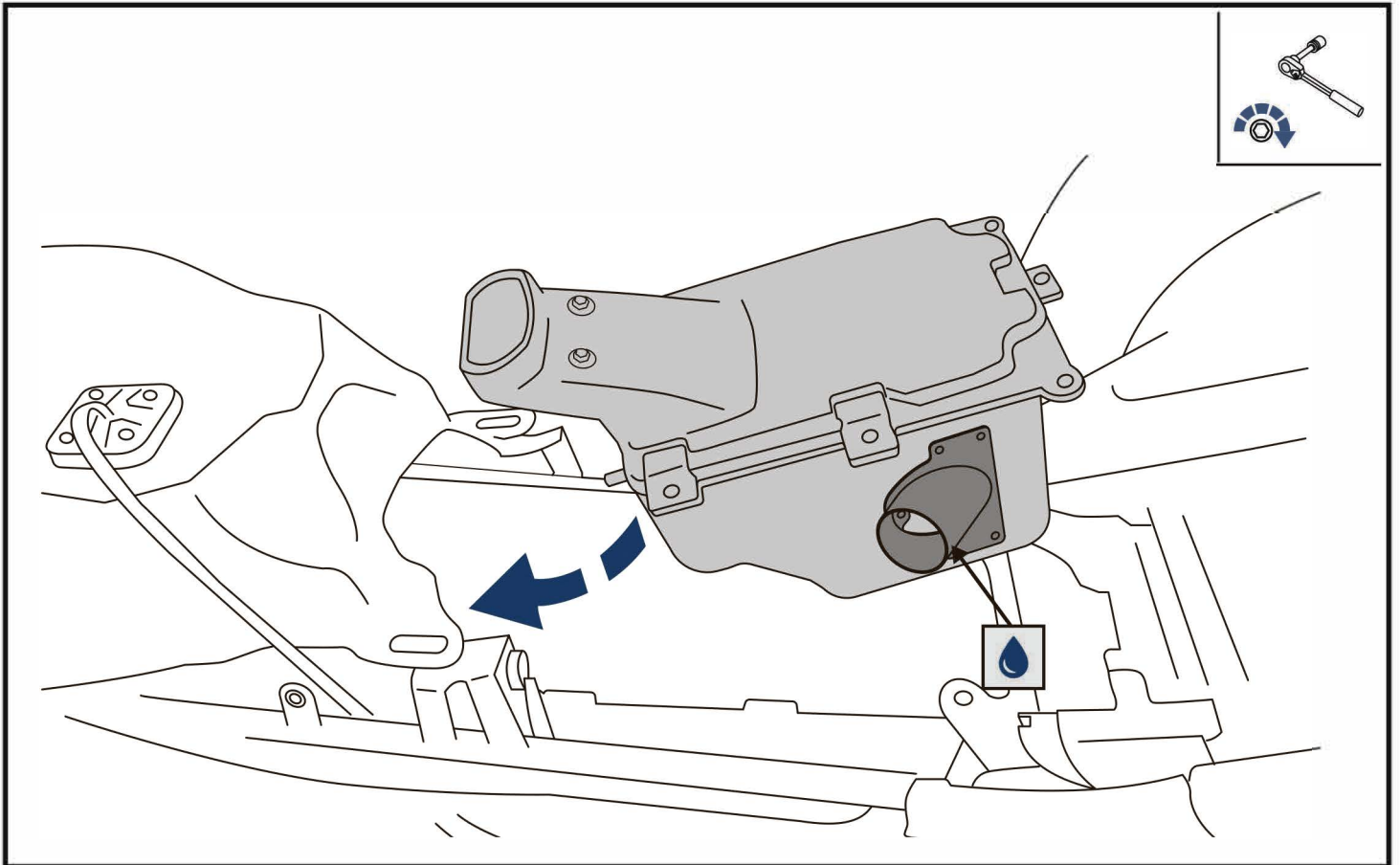



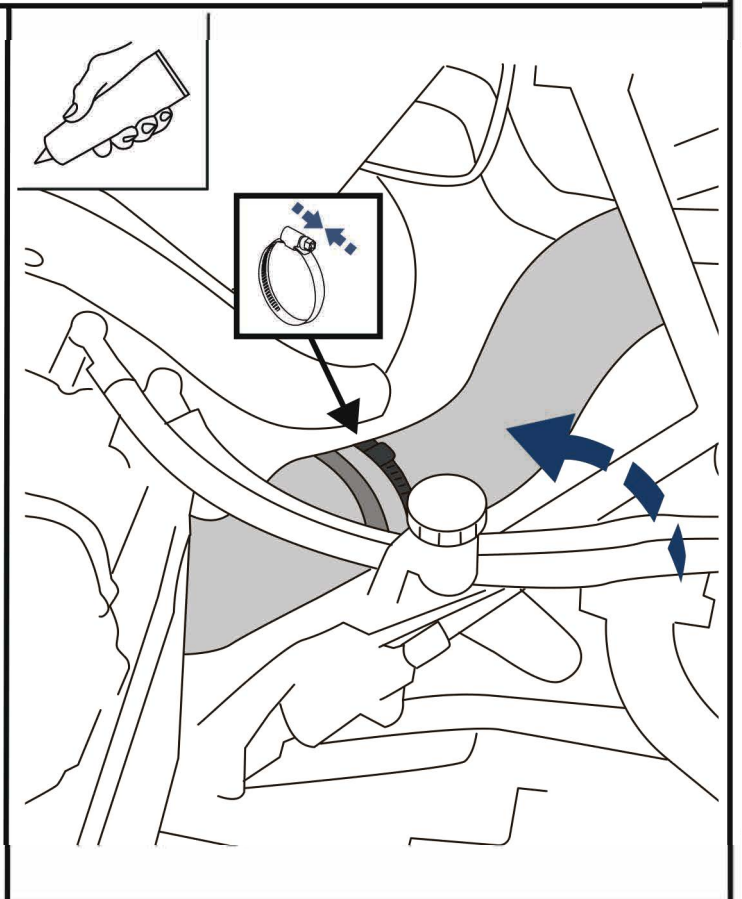
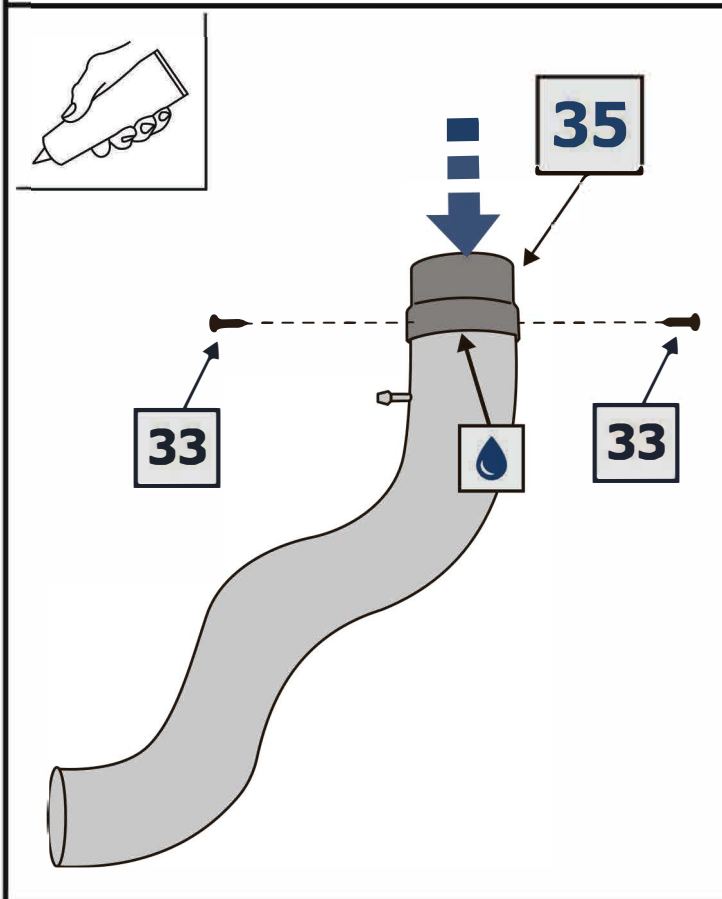
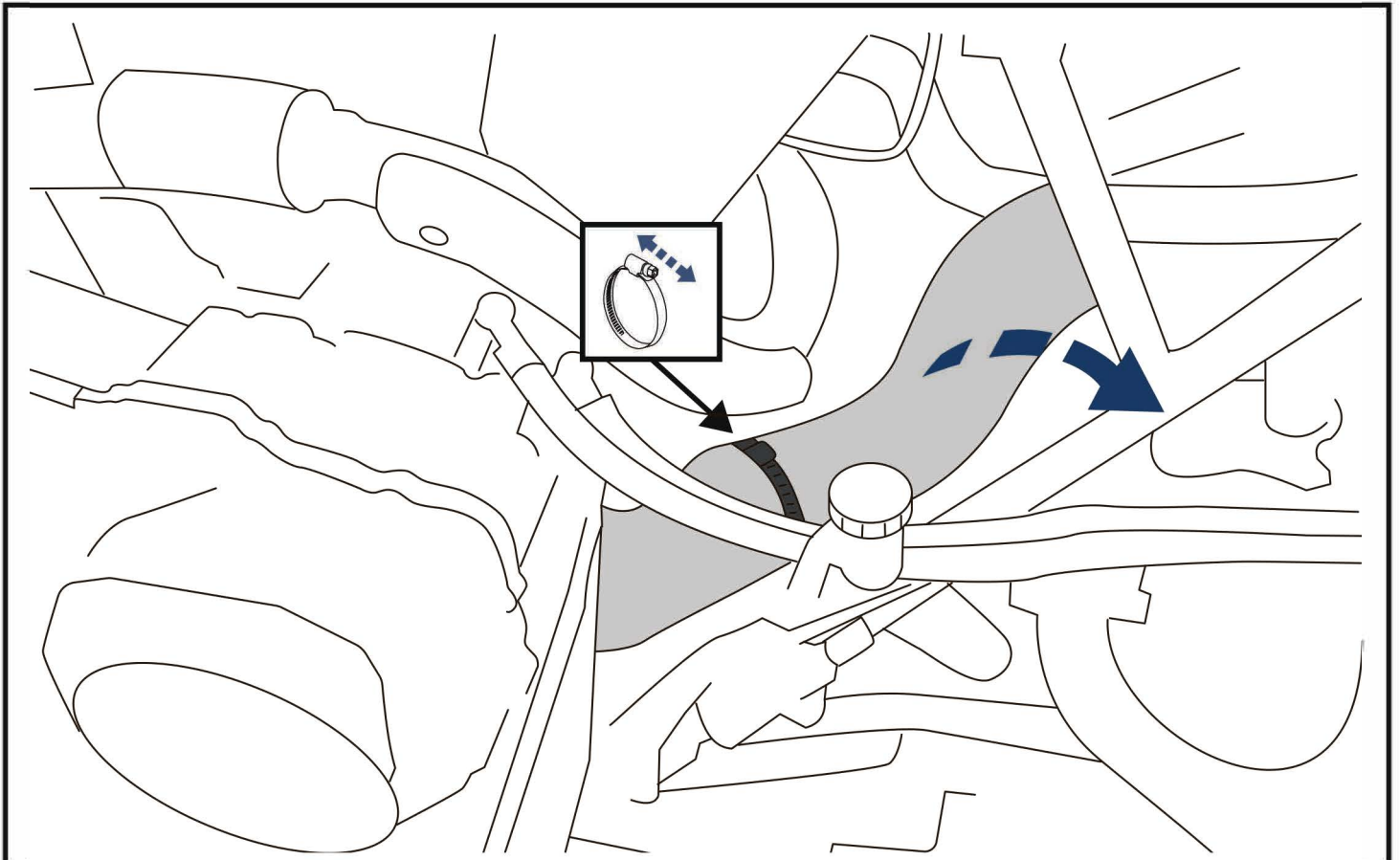

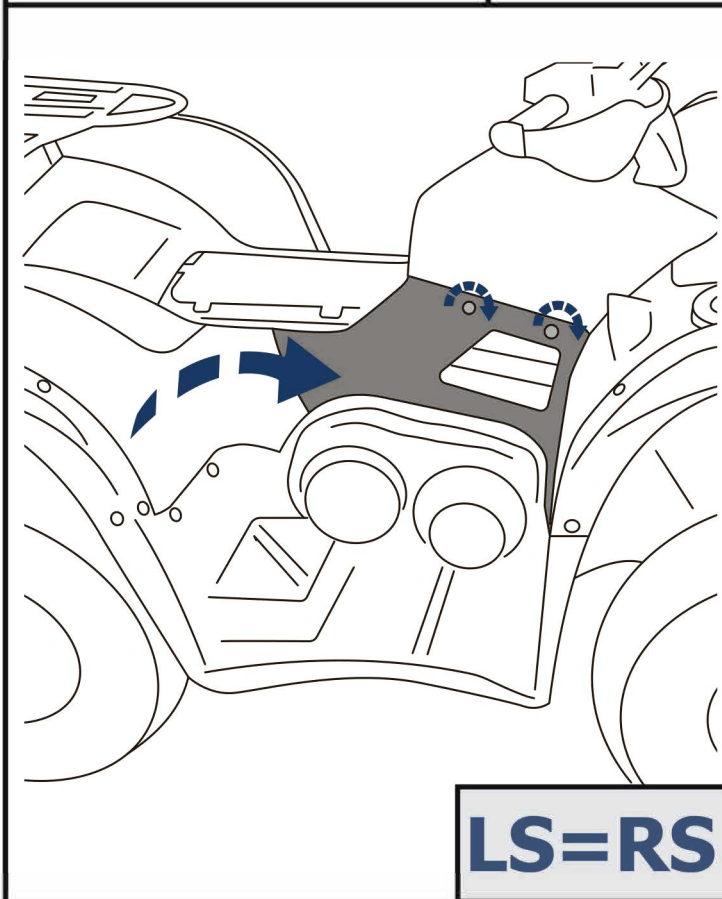
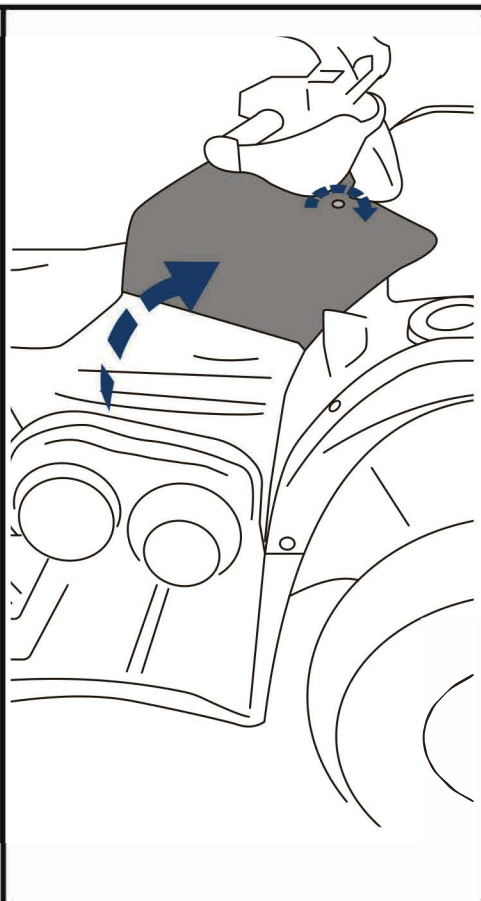
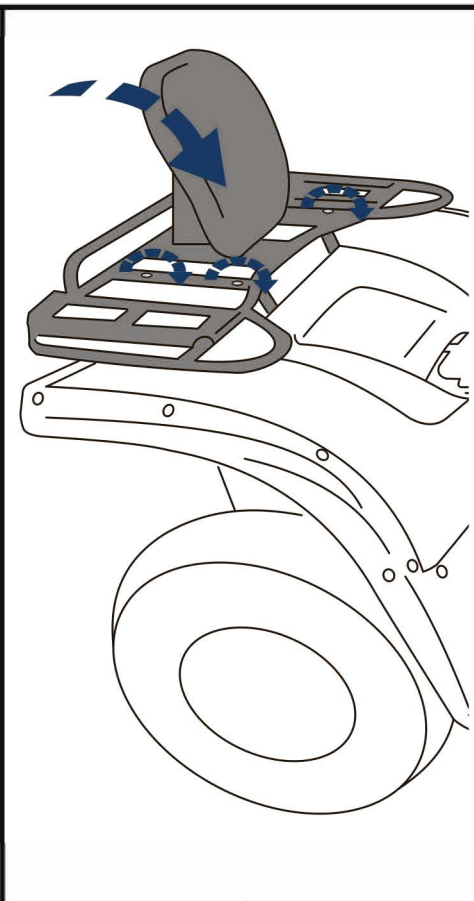
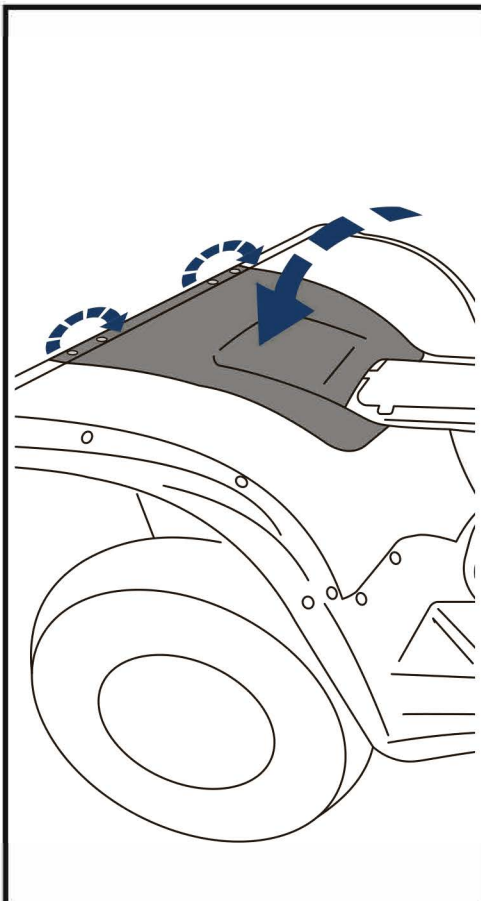

**LS=RS**

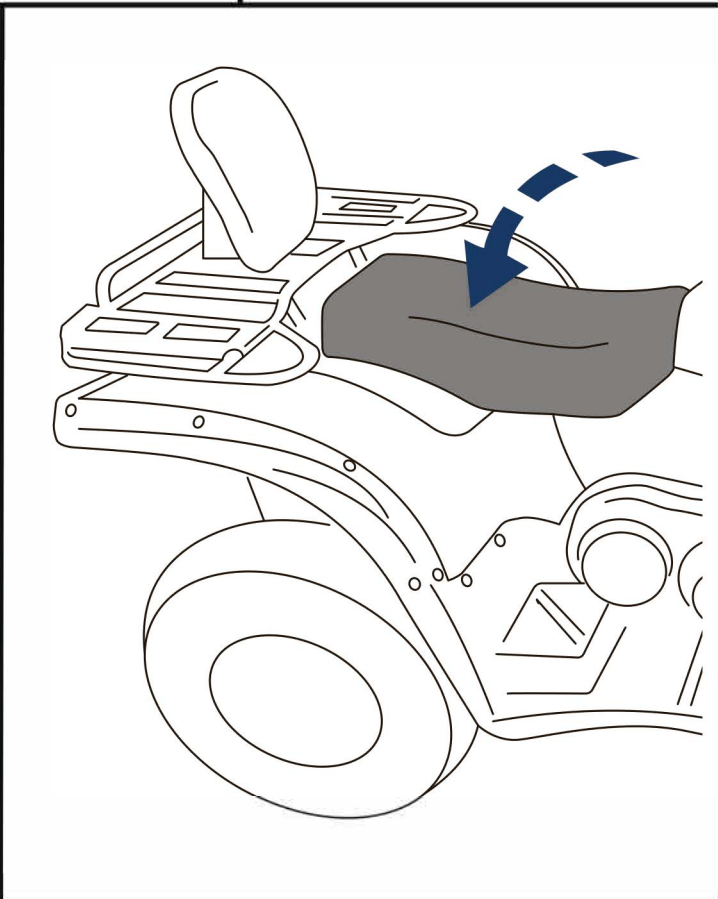

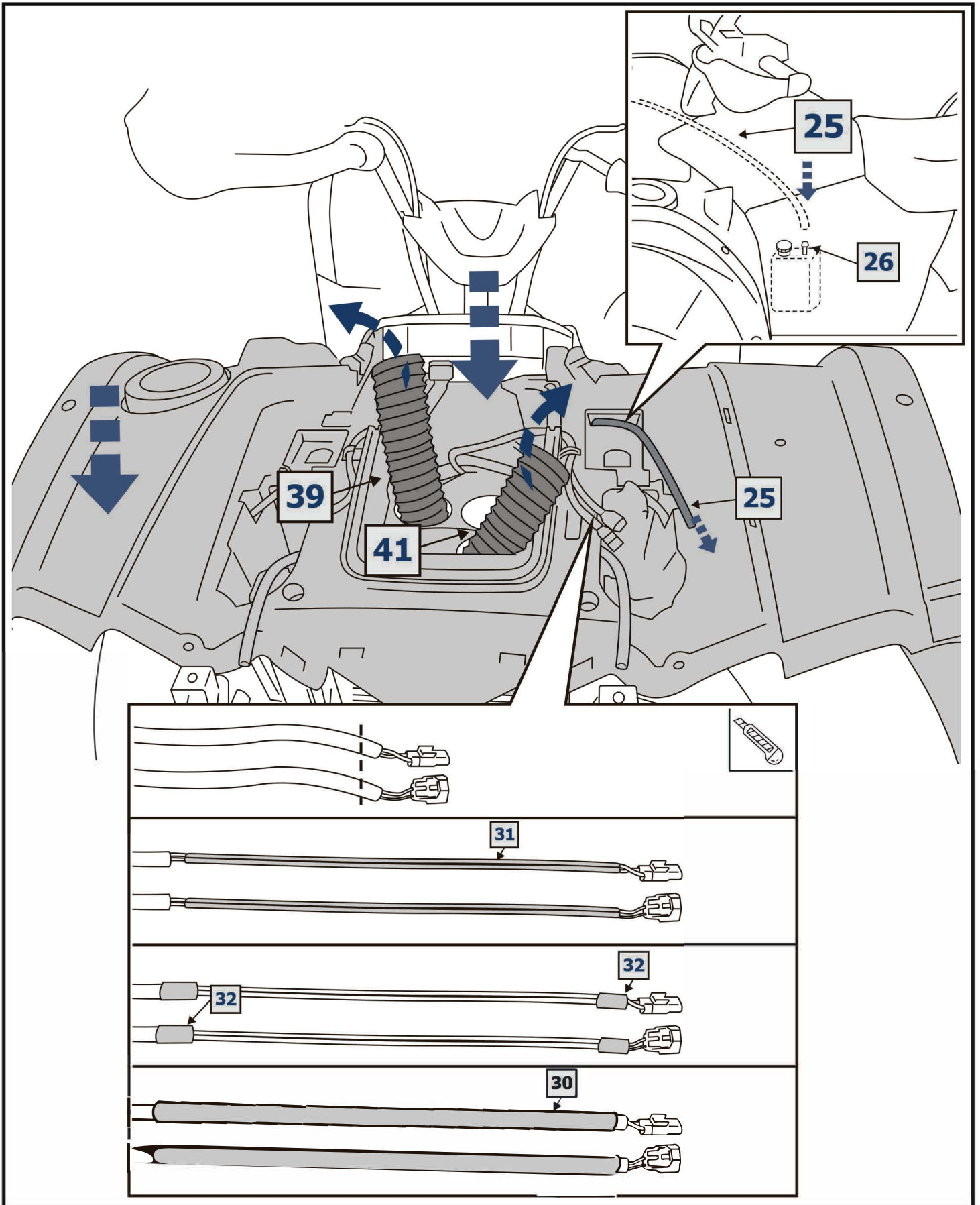



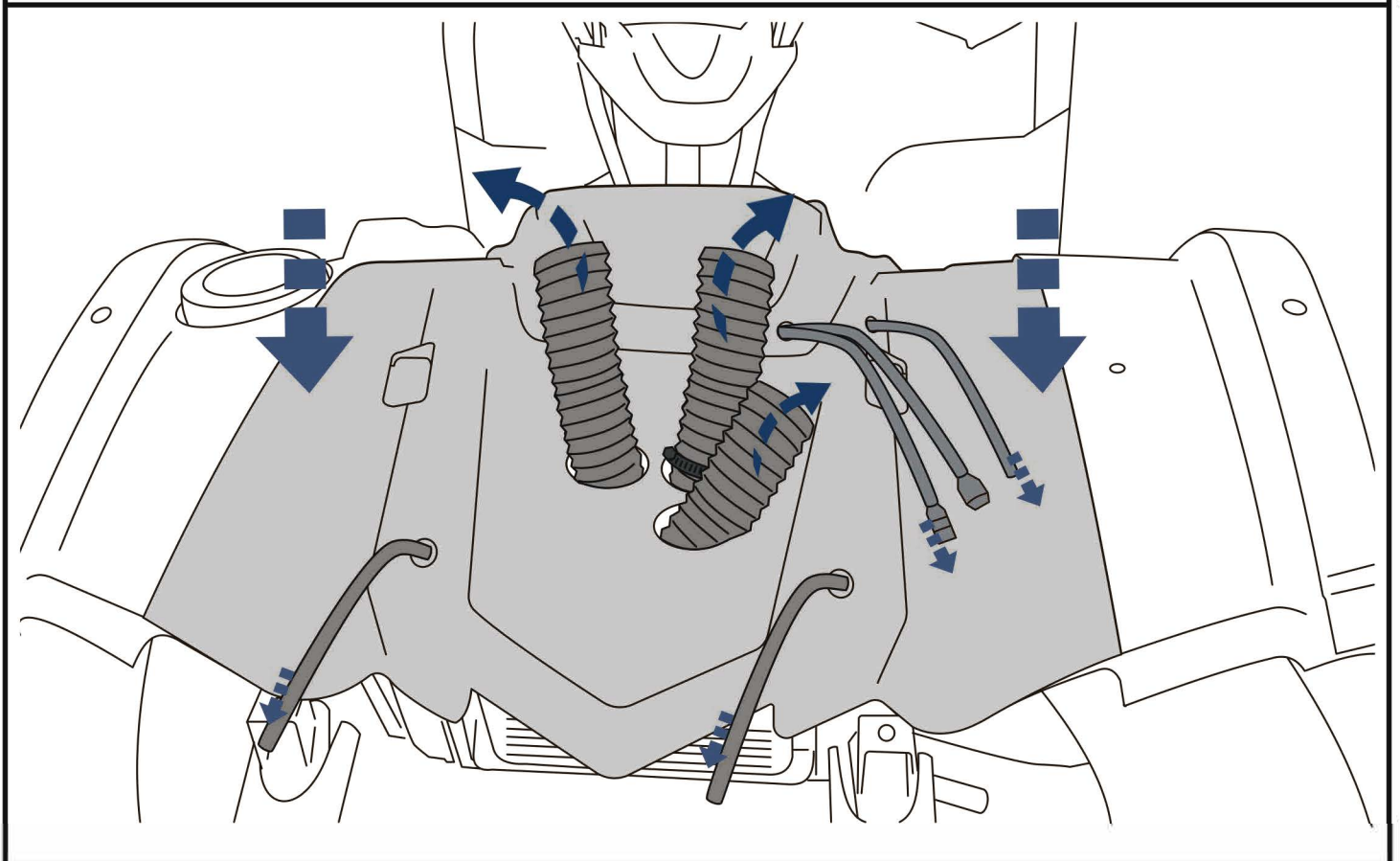
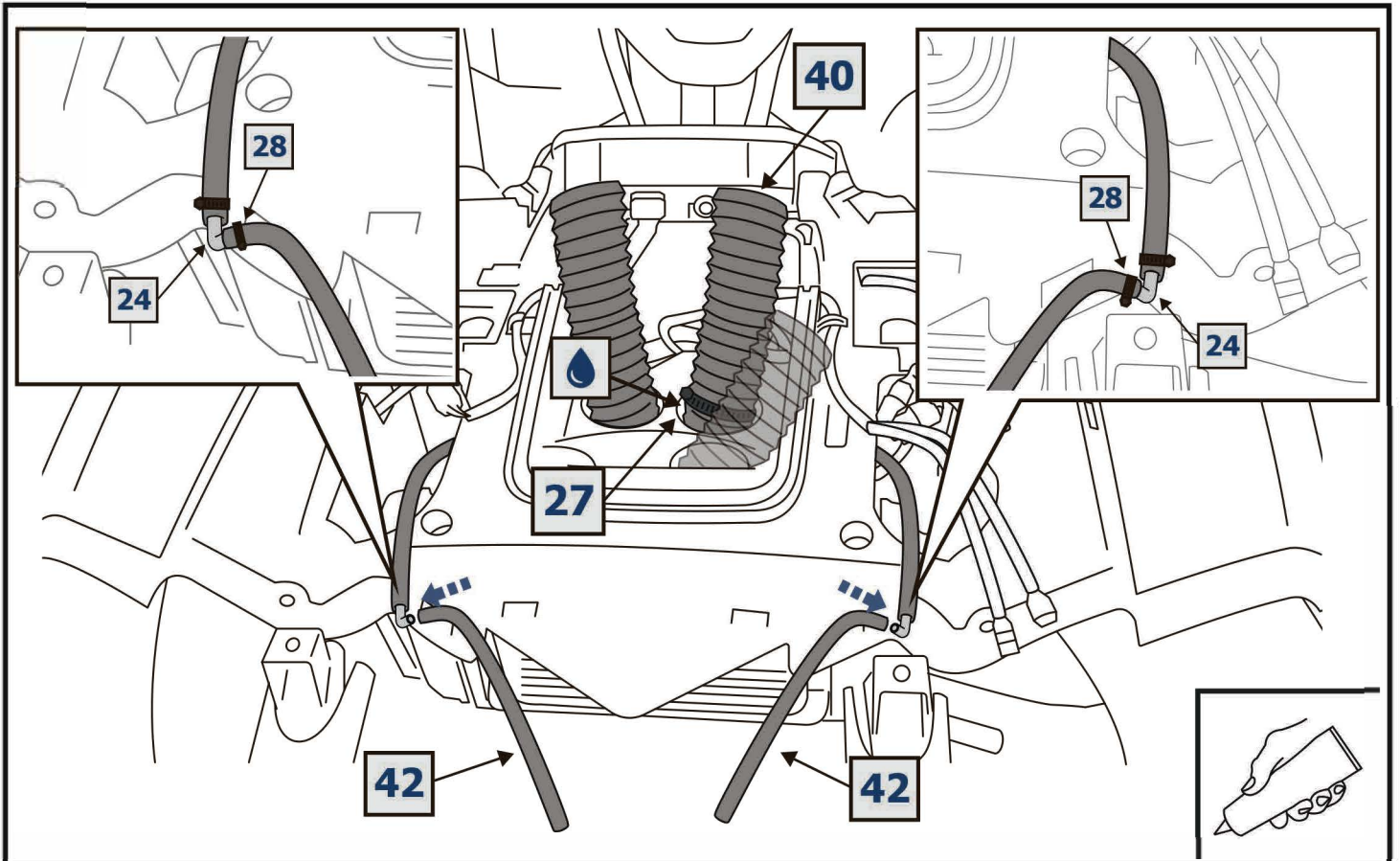



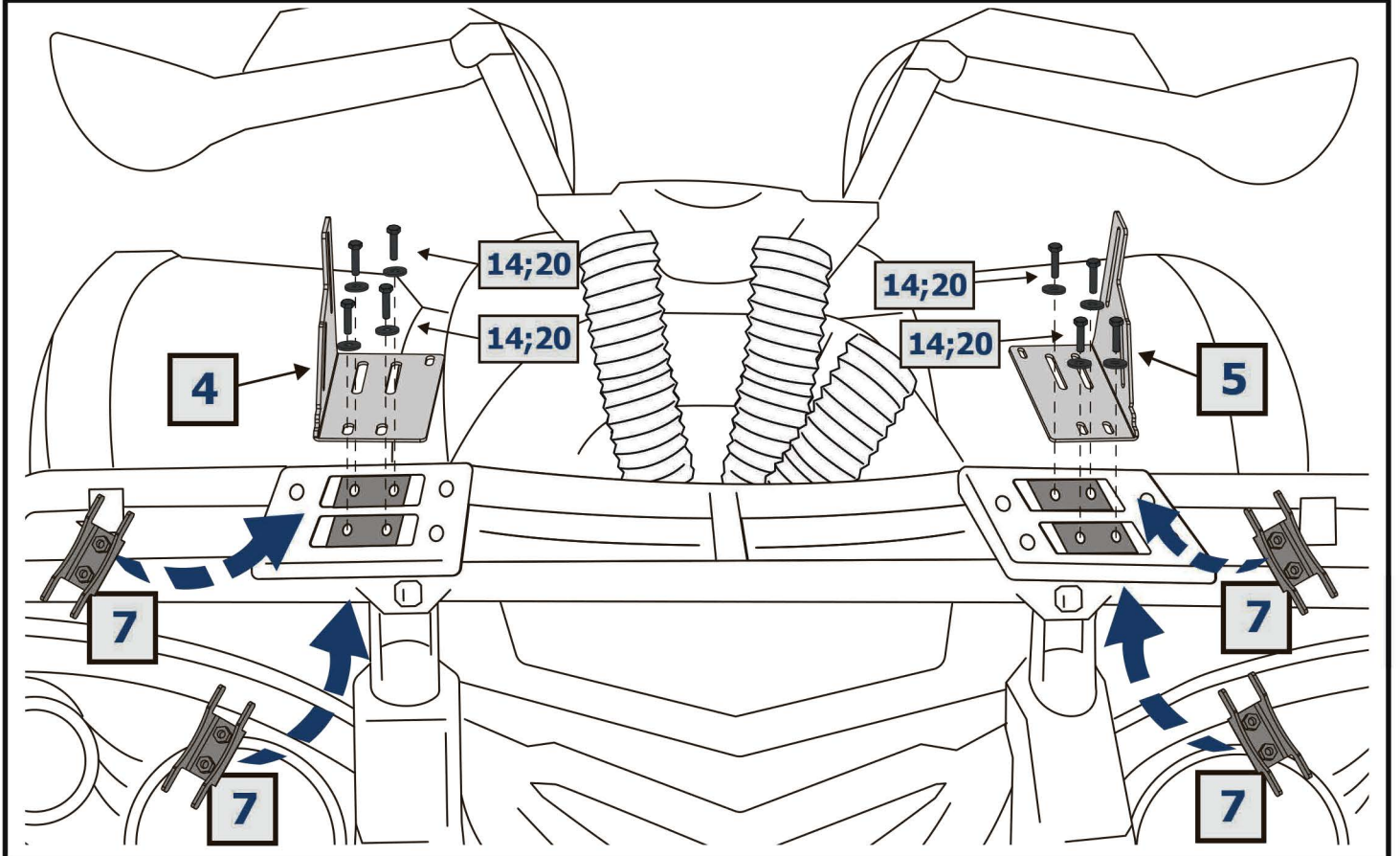
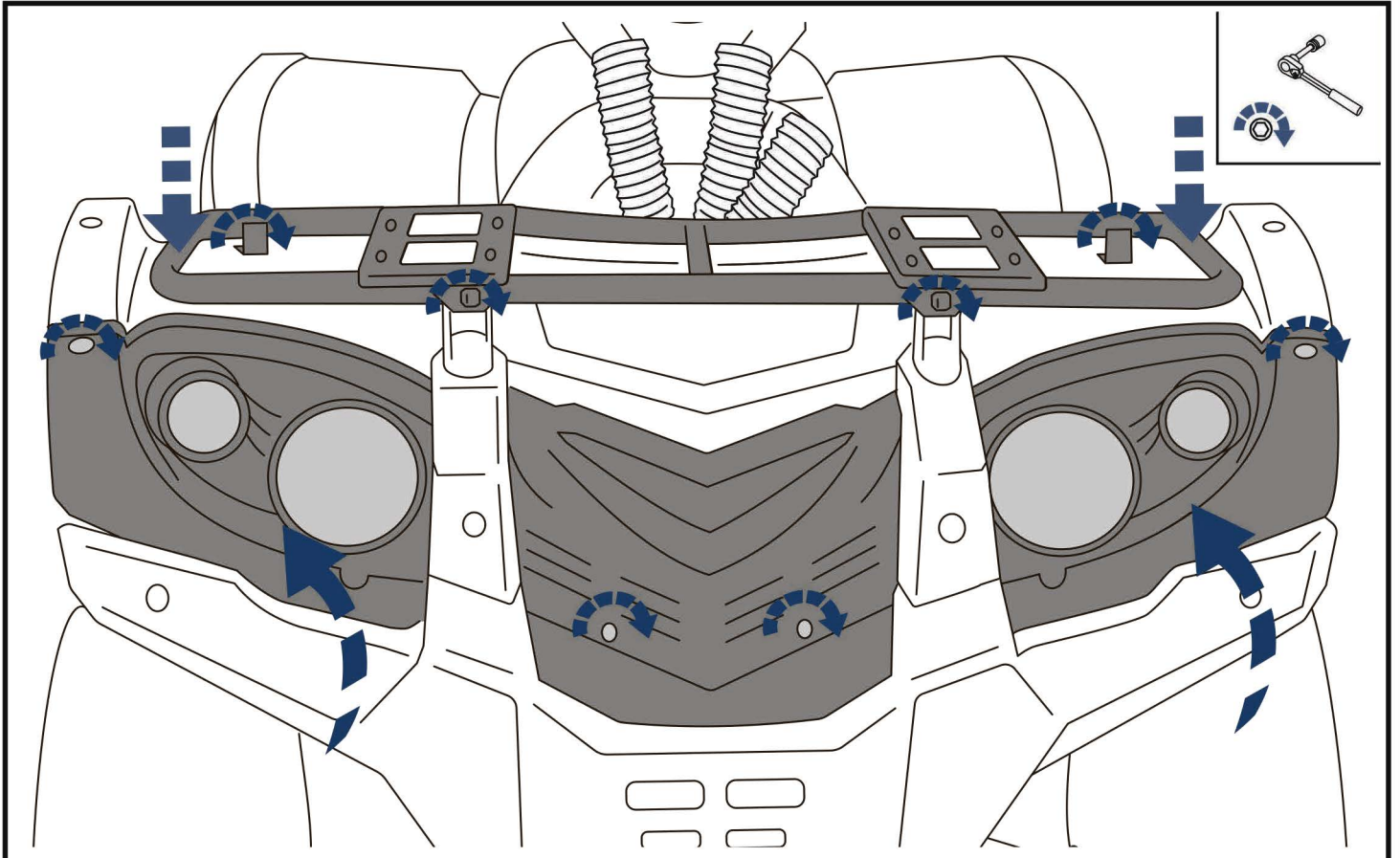

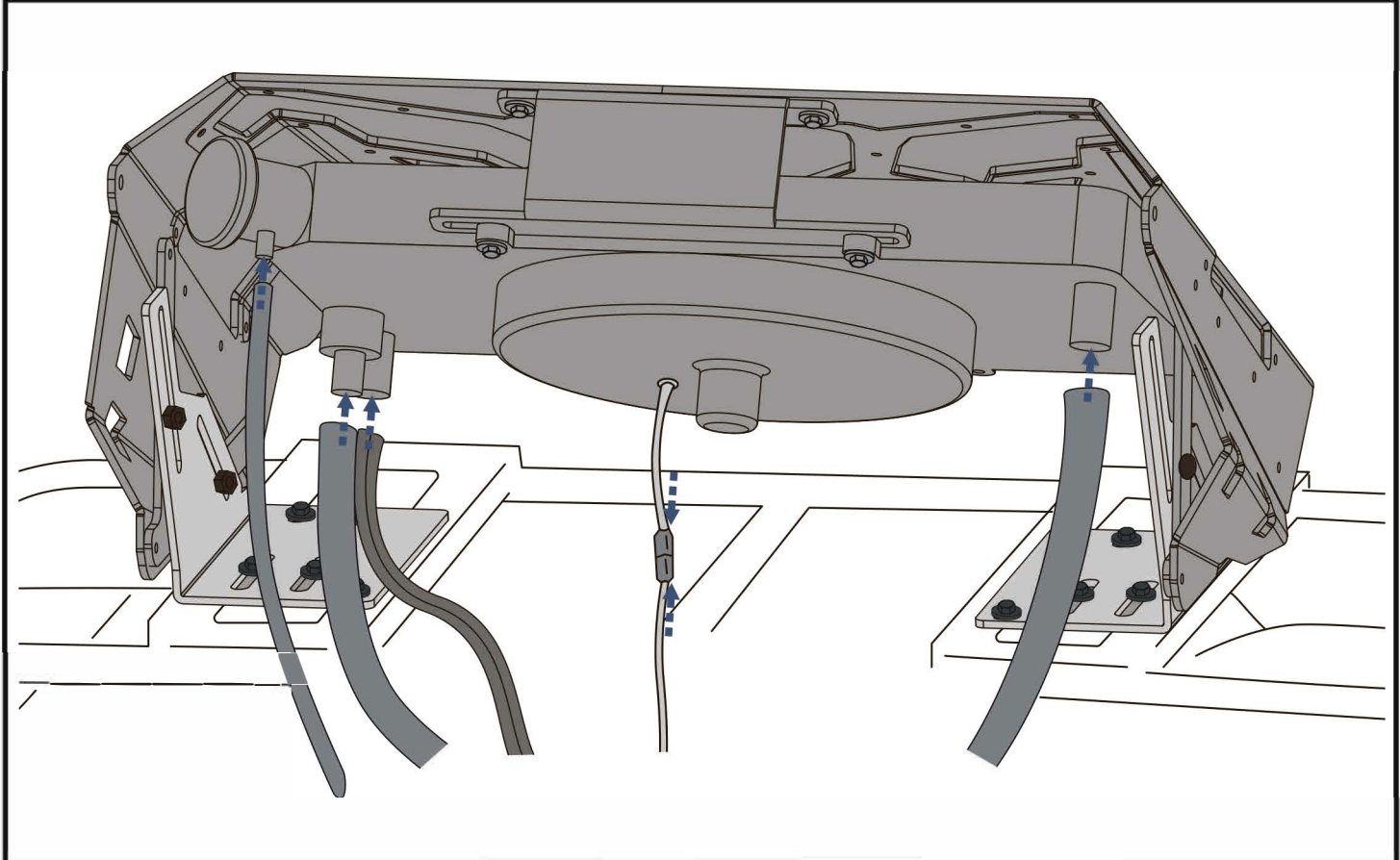
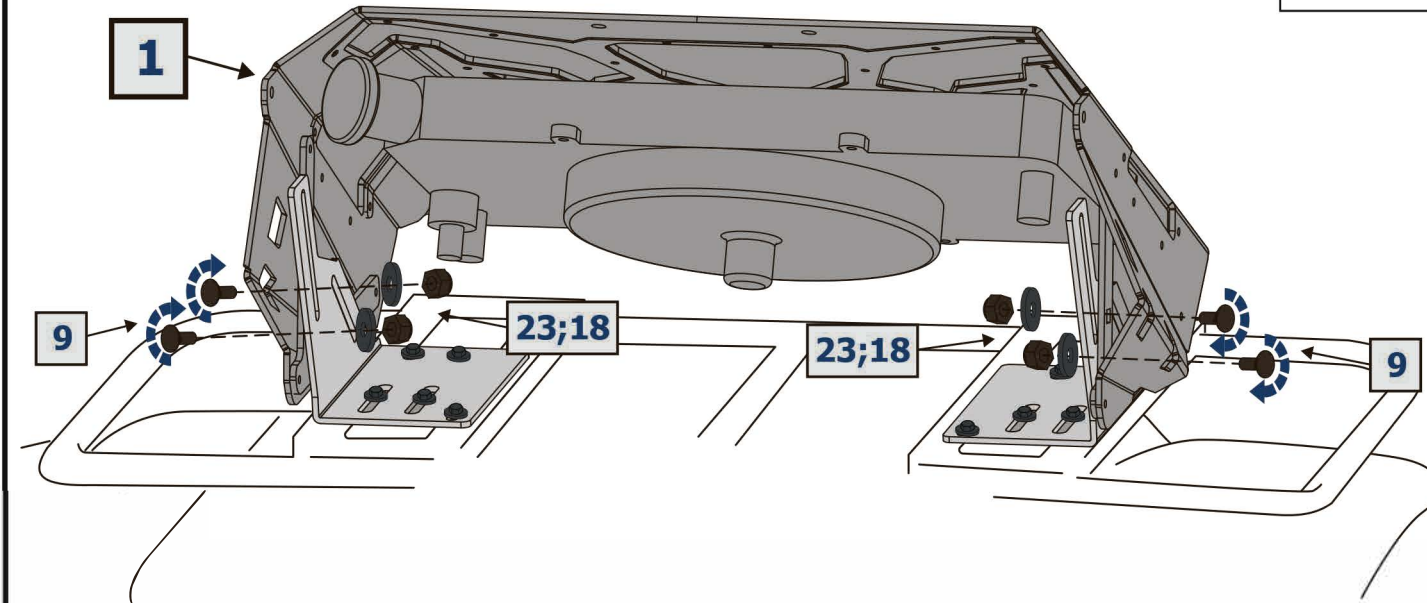



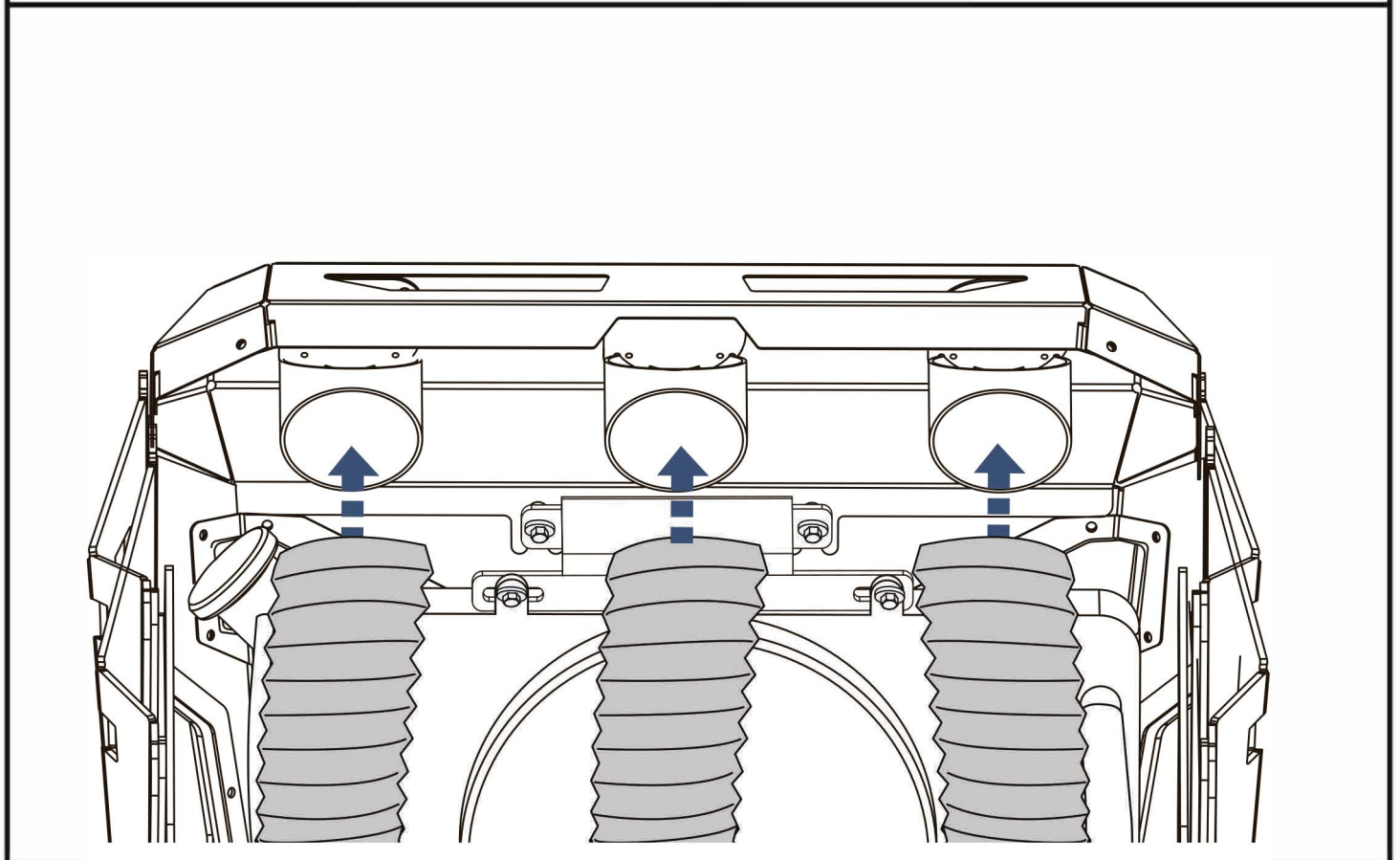
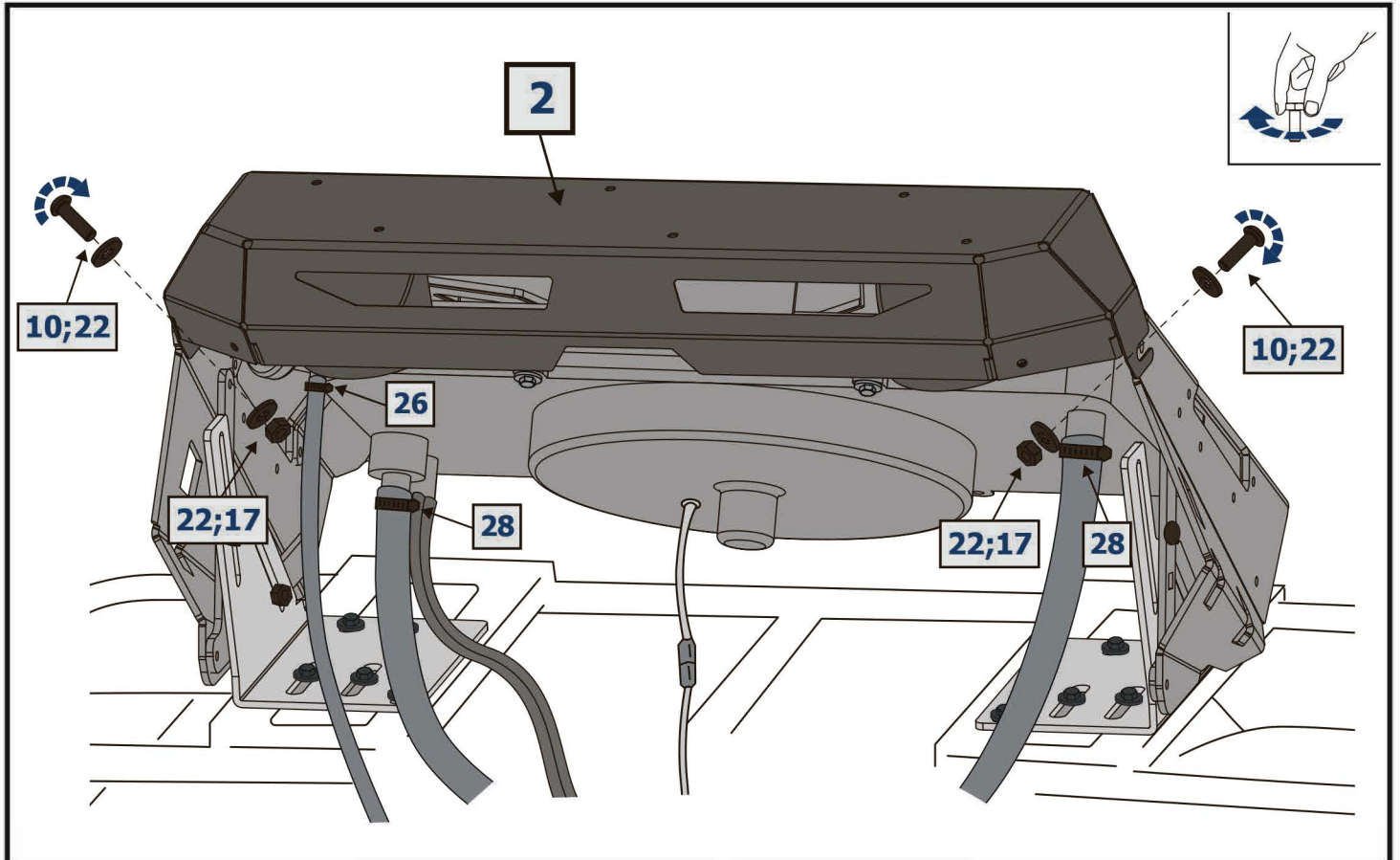

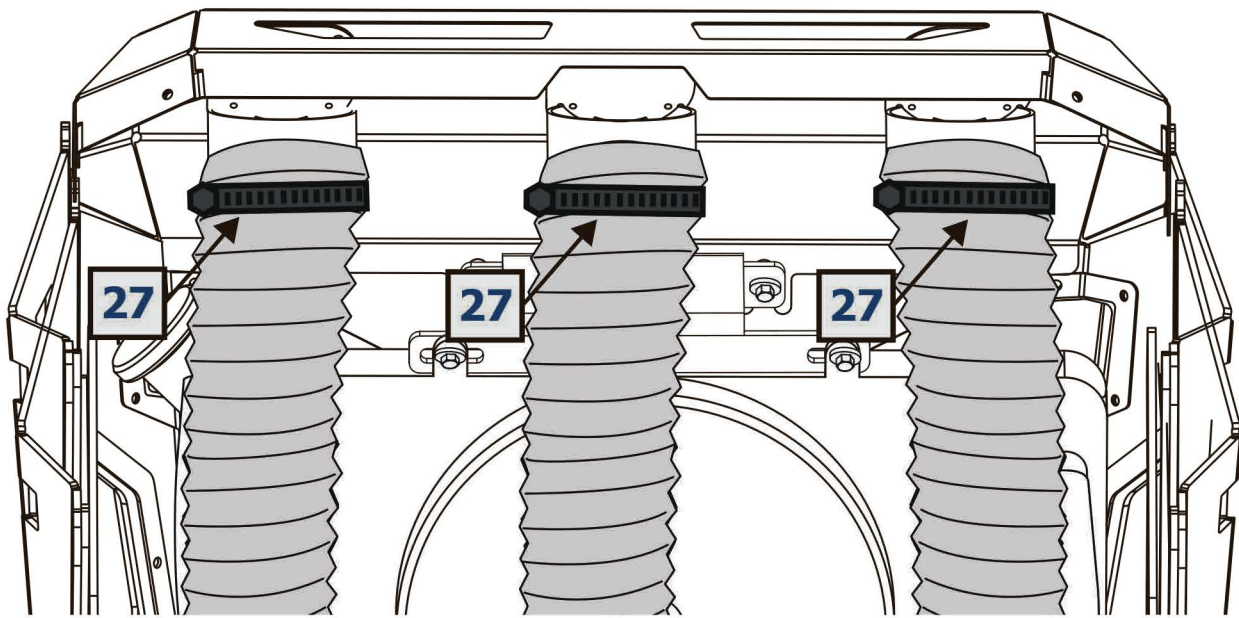



**EN** Attach temperature sensor connectors, fan connector and fan breather connector. For complete adjustment of the overhang by inclination angle, extend wires when necessary pos. **30, 31, 32**.

**DE** Schließen Sie die Steckverbindungen des Temperatursensors, den Stecker des Ventilators und des Entlüfters an. Für die vollständige Einstellung der Austragung je nach dem Anstellungswinkel verlängern Sie soweit erforderlich Kabel an der Positionen **30, 31, 32**.

**RU** Подсоединить разъемы датчика температуры, разъем вентилятора и сапуна вентилятора. Для полной регулировки выноса по углу наклона при необходимости удлинить провода поз. **30, 31, 32**.

**EN** Provide strong fastening of all branch pipes by zap straps pos. **29** to the frame and between each other in a way that they do not touch sharp edges under the luggage rack platform. As branch pipes are movable when being higher than the luggage rack platform due to adjustment of the relocation kit by inclination angle, please prevent touching of branch pipes and the hood and the luggage rack platform in order not to allow their abrasion.

**DE** Befestigen Sie alle Stützen mit Hilfe der Spannschellen (Position **29**) sicher zum Gestell und zueinander so, dass sie die scharfen Ränder unterhalb dem Gepäckraum nicht berühren. Da die Stützen über dem Gepäckraum wegen der Einstellung der Austragung je nach dem Anstellungswinkel beweglich sind, müssen sie mit der Haube und dem Gepäckraum nicht berühren, um deren Scheuern zu vermeiden.

**RU** Все патрубки надежно закрепить хомутами-стяжками поз. **29** к раме и между собой так, чтобы они не касались острых граней ниже багажной площадки. Так как выше багажной площадки патрубки подвижны из-за регулировки выноса по углу наклона, необходимо исключить касание патрубков с капотом и багажной площадки, во избежание их перетирания.